

LITHIUM HANDBOOK

INDUSTRIAL BATTERIES FOR PROFESSIONALS

APPLICATIONS

- Electronic Toll Collection (ETC)
- RFID
- Emergency call (E-Call)
- Gas meter
- Heat cost allocator
- Door lock system
- Marine devices
- Scales
- Remote Keyless Entry (RKE)
- Watch
- Glucose meter
- Remote control
- Ticketing machine
- Digital thermometer
- Real Time Clock (RTC)
- Medical devices, etc.

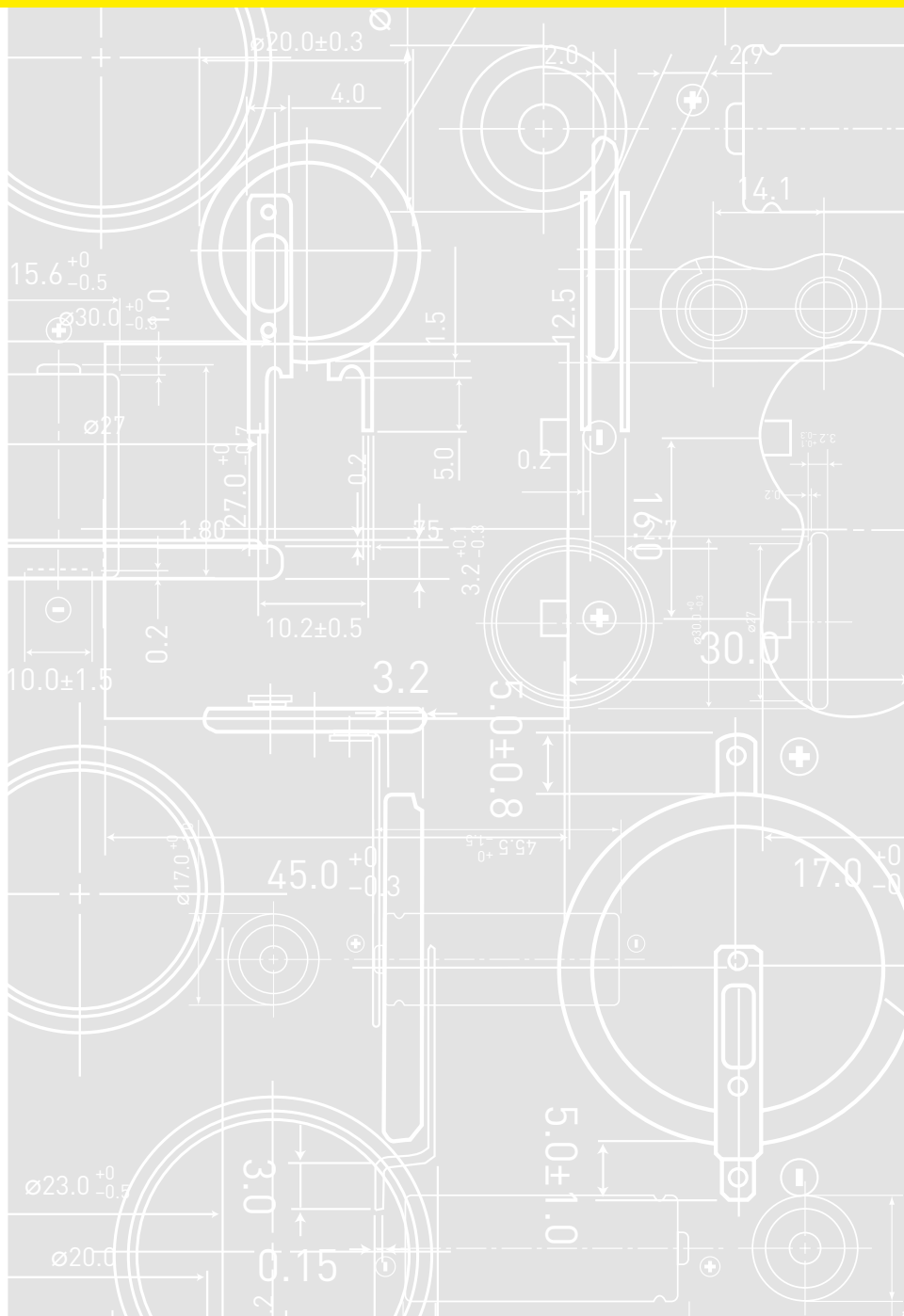
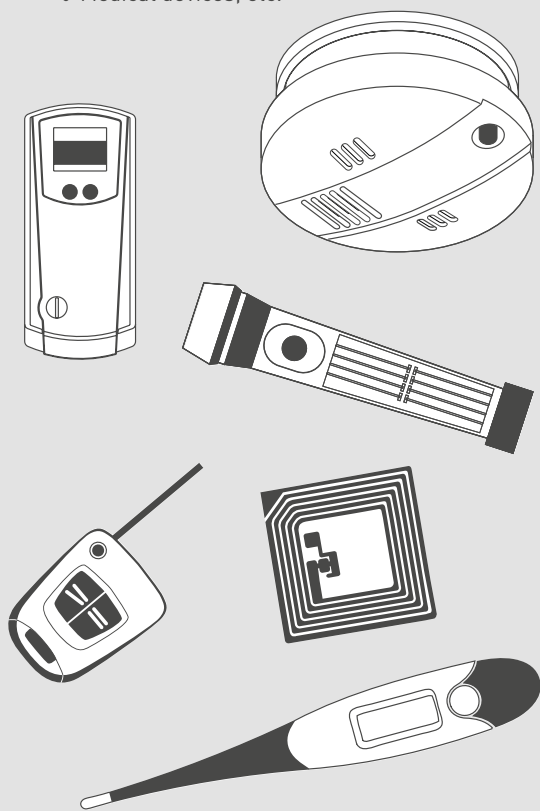

WORLD'S LARGEST BATTERY MANUFACTURER



PANASONIC ENERGY



Panasonic offers a wide range of power solutions for portable and stationary applications. Our product range includes high reliability batteries such as Lithium-Ion, Lithium, Nickel-Metal-Hydride, Nickel-Cadmium, Valve-Regulated-Lead-Acid (VRLA), Alkaline and Zinc-Carbon. With this breadth and depth to the portfolio, we can power your business in virtually all applications.

Panasonic began manufacturing batteries in 1931 and is today the most diversified global battery manufacturer worldwide, with an extensive network of manufacturing companies globally. The company employees are dedicated to research, development and production of batteries for an energised world.

PANASONIC AUTOMOTIVE & INDUSTRIAL SYSTEMS EUROPE GMBH (PAISEU)

Panasonic Corporation, founded in Osaka 1918, is one of the world's largest manufacturers of quality electronic and electrical equipment. Its subsidiary, Panasonic Automotive & Industrial Systems Europe GmbH (PAISEU), markets a diverse portfolio of industrial products throughout Europe. Formed in 2014 to strengthen Panasonic's pan-European industry operations, the company is now active in Automotive, Industry, Factory Solutions and Energy.

In October 2014, Panasonic Automotive & Industrial Systems Europe GmbH (PAISEU), Sanyo Component Europe GmbH (SCE) and Panasonic Industrial Devices Sales Europe GmbH (PIDSEU) merged and now operate as one AIS (Automotive & Industrial Systems) company. In addition, Panasonic Electric Works Europe AG (PEWEU) became a wholly owned subsidiary of PAISEU in October 2014. This new organisation reinforces Panasonic's position in the market, creating a stronger business partner for customers, who benefit from the capabilities and technical solutions of the combined product and service portfolios.

PAISEU organisation

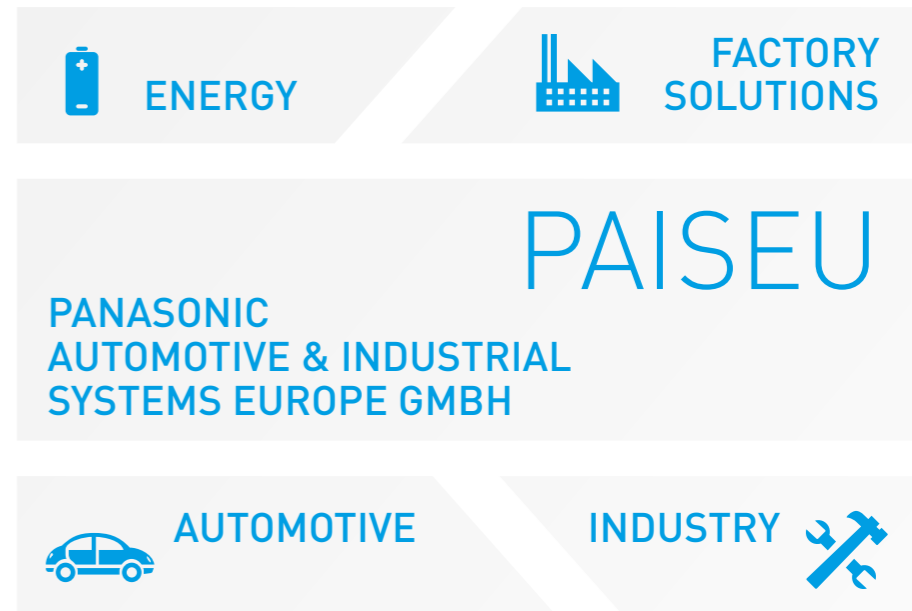

CERTIFICATIONS

'Quality is our Business' – this is what Panasonic stands for. It is the principle for all our batteries and supporting services. This commitment is confirmed by numerous certifications.

Our production facilities use leading-edge manufacturing processes that meet the toughest quality standards. All our factories are certified to ISO standards – with ISO 9000 and ISO 14000 being the minimum benchmarks. This means each factory has its own quality and environmental management, and delivers products that measure up to toughest standards of reliability.

Most of our factories are also certified to OHSAS 18001 (Occupational Health and Safety Assessment Series), an international standard to assess the management system which organisations have in place for occupational safety. This confirms that our factories have been proactive in putting the occupational health and safety of staff at the centre of the company's dealings. In addition our VRLA batteries are for example approved to German VdS standard and the US UL standard.

Our batteries therefore offer benefits – power, safety, long life – which guarantee quality in every respect and deliver the best performance for your application. Find out how we can power your business.

Panasonic quality – certified by authorised agencies.



FIND THE RIGHT BATTERY FOR YOUR APPLICATION

App 2.1
and online version

BATTERY FINDER app & find

FEATURES

Designed for engineers, electronics specialists and developers who need batteries for their projects, the Battery Finder provides an overview of what's available in the Panasonic range of industrial batteries, and gives a recommendation on the type of battery that's best suited to the user's application. It also offers a wealth of information, diagrams and videos on battery technology.

- ⊗ Search for batteries using three filter criteria:
 - Search by product series (chemistries)
 - Search by application
 - Search by model number
- ⊗ Current Panasonic range: now 307 batteries
- ⊗ Automatic update of range
- ⊗ Pictures and technical drawings of all products
- ⊗ Product datasheets
- ⊗ Favorites selection and sending to interested person
- ⊗ Function for comparing batteries based on technical details (only online application)
- ⊗ Function for requesting product material in hardcopy or PDF format
- ⊗ Function for recommendation
- ⊗ Function for sending an inquiry
- ⊗ Extensive information on battery technology ('What is' glossary)
- ⊗ Videos showing battery structure
- ⊗ Information about the company
- ⊗ Panasonic green battery application video
- ⊗ All contact details for Panasonic Automotive & Industrial Systems Europe GmbH
- ⊗ Function to save images to smartphone gallery
- ⊗ Direct link to Panasonic Battery Channel on YouTube

There are two versions of the Battery Finder: a smartphone app for iPhone and Android devices (2.1) and an online application for computers or tablets.

SMARTPHONE APP

App version 2.1

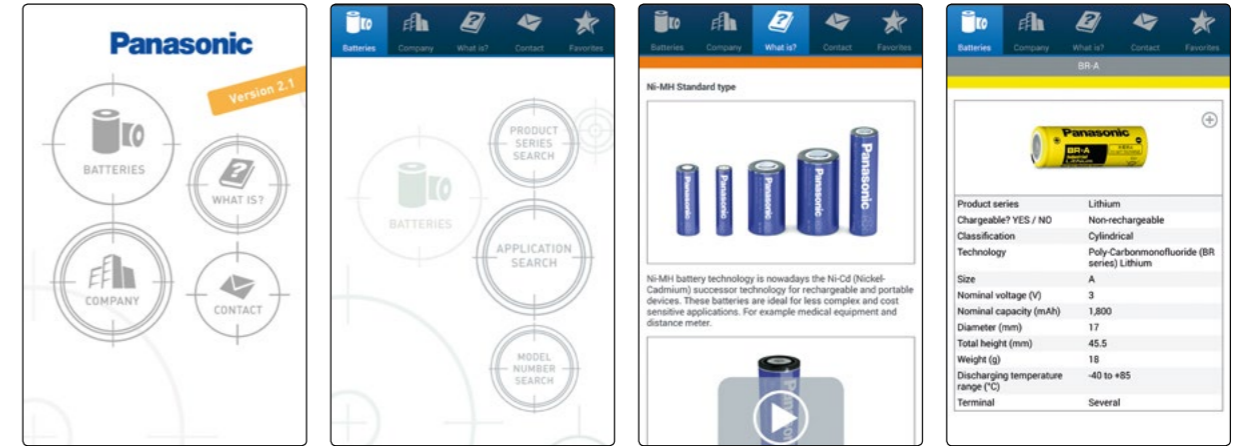

HOME

This is the welcome screen. You can start looking for a battery straight from here, or check out the information on Panasonic and details on battery technologies. Good luck!

BATTERY FINDER

You can search for the batteries in three ways: by battery straight from here, or check out the information on Panasonic and details on battery technologies. Good luck!

WHAT IS?

If you're looking for background info, you'll find it here in the app's extensive glossary on battery technology. Find out about our battery types, product series and terminal types.

BATTERY INFORMATION

You're shown the selected battery with all the key details. You have also several options for requesting downloads and hardcopies.

HTML APP

Online version

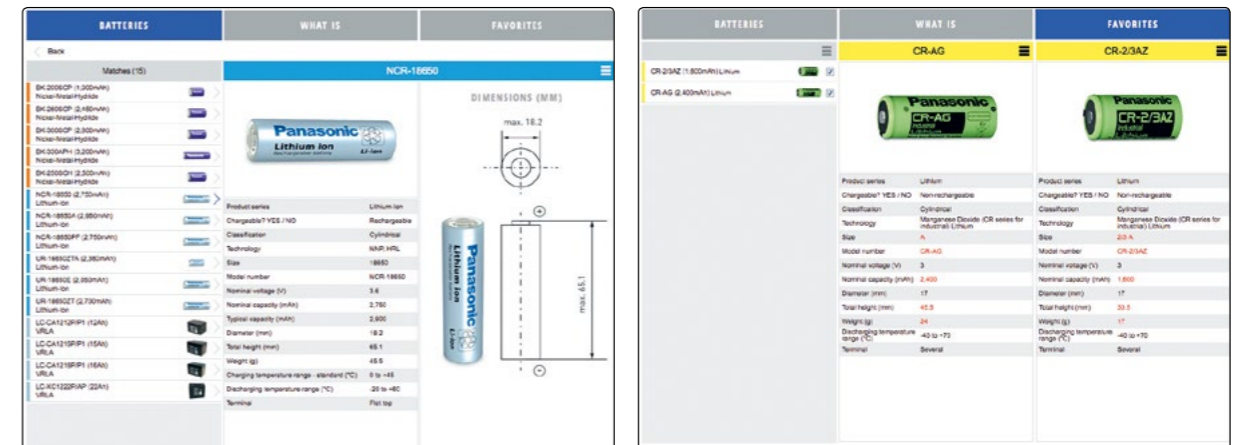









TECHNICAL INFORMATION

If you're looking for background info, you'll find it here – in the app's extensive glossary on battery technology. Find out about our battery types, product series and terminal types.

BATTERY COMPARISON

You have the option to display two batteries simultaneously. The differences between the products are automatically highlighted.

DOWNLOAD THE RIGHT BATTERY MEDIA FILES

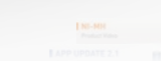
ALKALINE (45) 	LITHIUM (460) 	LITHIUM-ION (272) 
NICKEL-CADMIUM (220) 	NICKEL-METAL-HYDRIDE (212) 	VRLA (370) 
ZINC-CARBON (45) 	GENERAL PICTURES (90) 	VIDEOS (14) 



FIND THE RIGHT BATTERY VIDEO

FEATURES



The Panasonic Mediapool is a complete online library of Panasonic battery images, videos and press releases, providing you with just the right material for all sorts of projects. The Mediapool is open to all visitors to the Panasonic website, and offers material for both print and web. The image files differ with respect to their resolution (image size) and color space (CMYK or RGB). For each product, there is also a version with a shadow (suitable for use on a white background) and without shadow (suitable for use on a colored or grey background). The library contains images in three formats: JPG, EPS and PNG.

New

- New chemistry Ni-Cd (Nickel-Cadmium)
- Videos and press releases now available, in addition to pictures
- New files appear in the folder 'New files' for three months

You can assemble as many files as you need and download them directly to your computer. Here's an overview of what you can do:

- Locate the material you need by product name or by clicking through the categories
- Preview file details – the preview function tells you the full name of the file, its size, format and resolution
- Select the files you wish to download. You can take files from multiple folders, or select all the material in a particular folder or category in one-click operation – there's no need to select each one individually
- Preview your personal 'Download bag' of the files you have selected
- The Mediapool zips your data into a file, which you then download to your computer. You unzip the file to the location of your choice simply by double-clicking the file name. The material is then ready for use.

PANASONIC IN MOTION



Please find a comprehensive selection of Panasonic battery videos at our YouTube Channel. You can find videos about the inner structure of our different battery chemistries, a video which gives you a clear insight about 'green' battery applications and last but not least a video which explains the working of our Battery Finder App in detail.

Find out how we can power your business!

PANASONIC GREEN BATTERY APPLICATION
Eco Ideas Video
Panasonic

PANASONIC GREEN BATTERY APPLICATION

NI-MH
Product Video
Panasonic

PANASONIC NI-MH PRODUCT VIDEO FOR PROFESSIONALS

ALKALINE
Product Video
Panasonic

PANASONIC ALKALINE PRODUCT VIDEO FOR PROFESSIONALS

APP UPDATE 2.1
Battery Finder Video
Panasonic

PANASONIC BATTERY FINDER UPDATE 2.1 – APP & ONLINE VERSION

CHAPTER	PAGE
COMPANY	2 - 3
BATTERY FINDER	4 - 5
MEDIAPOOL	6
YOUTUBE CHANNEL	7
1 GENERAL INFORMATION	9 - 27
SAFETY WARNINGS AND PRECAUTIONS	9
INTRODUCTION	10 - 11
GENERAL FEATURES	12 - 13
PRIMARY VS. RECHARGEABLE LITHIUM BATTERIES	14
APPLICATIONS	15
SELECTING A BATTERY/MODEL NUMBER	16 - 17
BATTERY SELECTION CHART	18 - 22
GENERAL SAFETY PRECAUTIONS FOR USING, HANDLING AND DESIGNING	23 - 26
DESIGN FOR MEMORY BACK-UP USE	27
2 PRIMARY LITHIUM BATTERIES - INDIVIDUAL DATA SHEETS	28 - 59
POLY-CARBONMONOFLUORIDE LITHIUM BATTERIES (BR SERIES) - CYLINDRICAL TYPE	29 - 32
MANGANESE DIOXIDE LITHIUM BATTERIES (CR SERIES FOR CONSUMER) - CYLINDRICAL TYPE	33 - 36
MANGANESE DIOXIDE LITHIUM BATTERIES (CR SERIES FOR PROFESSIONALS) - CYLINDRICAL TYPE	37 - 38
POLY-CARBONMONOFLUORIDE LITHIUM BATTERIES (BR SERIES) - COIN TYPE	39 - 43
i HIGH TEMPERATURE POLY-CARBONMONOFLUORIDE LITHIUM BATTERIES (BR-A SERIES) - COIN TYPE	44 - 47
MANGANESE DIOXIDE LITHIUM BATTERIES (CR SERIES) - COIN TYPE	48 - 57
POLY-CARBONMONOFLUORIDE LITHIUM BATTERIES (BR SERIES) - PIN TYPE	58 - 59
3 RECHARGEABLE LITHIUM BATTERIES - INDIVIDUAL DATA SHEETS	60 - 76
VANADIUM RECHARGEABLE LITHIUM BATTERIES (VL SERIES) - COIN TYPE RECHARGEABLE	61 - 66
MANGANESE RECHARGEABLE LITHIUM BATTERIES (ML SERIES) - COIN TYPE RECHARGEABLE	67 - 72
TITANIUM RECHARGEABLE LITHIUM BATTERIES (MT SERIES) - COIN TYPE RECHARGEABLE	73 - 76
4 LITHIUM BATTERY TERMINALS AND SOLDERING	77 - 79
BATTERY TERMINALS	78
SOLDERING LITHIUM BATTERIES	78
TERMINAL TYPES	79
5 STANDARDS AND REGULATIONS	80 - 81
PRODUCT CERTIFICATIONS	80
FACTORY CERTIFICATIONS	80
APPLICABLE STANDARDS	80
LITHIUM BATTERY TRANSPORTATION	80
SECURITY EXPORT CONTROL	80 - 81
6 AVOIDING HAZARDS AND PREVENTING QUALITY PROBLEMS	82 - 85
AVOIDING HAZARDS	82
PREVENTING QUALITY PROBLEMS	83 - 85

⚠ Please be sure to observe the following warnings. As batteries contains flammable substances such as Lithium or other organic solvents, they may cause heating, rupture or ignition.

CYLINDRICAL TYPE LITHIUM BATTERIES

⚠ Warning

1. It may cause rupture or ignite.
1. Do not charge, short (an exception is to pass batteries through dipping solder) disassemble, deform or heat batteries. Do not throw batteries into fire.
2. Do not connect the ⊕ and ⊖ electrodes to each other with metal or wire. Do not carry or store batteries together with a metallic necklace, etc.
3. Do not connect ⊕ and ⊖ terminals to devices.
4. Do not mix use of new and old batteries or batteries of other series.
5. Do not solder directly to batteries.
2. When discarding batteries, insulate the ⊕ and ⊖ terminals of batteries with insulating tape, etc. (see Fig. 1). When disposed of improperly, Lithium batteries may short, causing them to become hot, burst or ignite.
3. Keep batteries out of reach of small children. Should a child swallow a battery, consult a physician immediately.

⚠ Caution

Keep batteries away from direct sunlight, high temperature, and high humidity.

COIN TYPE LITHIUM BATTERIES

⚠ Warning

1. Do not charge, short (an exception is to pass batteries through dipping solder) disassemble, deform or heat batteries. Do not throw batteries into fire.
2. Keep batteries out of reach of small children. Should a child swallow a battery, consult a physician immediately.
3. When discarding batteries, insulate the ⊕ and ⊖ terminals of batteries with insulating tape, etc. (see Fig. 1). When disposed of improperly, Lithium batteries may short, causing them to become hot, burst or ignite.

⚠ Caution

1. Be sure to connect the ⊕ and ⊖ electrodes correctly.
2. Avoid mixed use of batteries, i.e. new, used or different types.

3. Avoid direct soldering to batteries.
4. Keep batteries away from direct sunlight, high temperature, and high humidity.

COIN TYPE RECHARGEABLE LITHIUM BATTERIES

⚠ Warning

1. Do not short-circuit (an exception is to pass batteries through dipping solder), disassemble, deform or heat batteries. Do not throw batteries into fire.
2. Do not charge rechargeable batteries with a higher voltage than specified.
3. Keep batteries out of reach of small children. Should a child swallow a battery, consult a physician immediately.
4. When discarding batteries, insulate the ⊕ and ⊖ terminals of batteries with insulating tape, etc. (see fig. 1). When disposed of improperly, Lithium batteries may short, causing them to become hot, burst or ignite.

⚠ Caution

1. Be sure to connect the ⊕ and ⊖ electrodes correctly.
2. Avoid mixed use of batteries, i.e. new, used or different types.
3. Avoid direct soldering to batteries.
4. Keep batteries away from direct sunlight, high temperature, and high humidity.

Fig. 1 When disposing batteries (example of insulating)*1

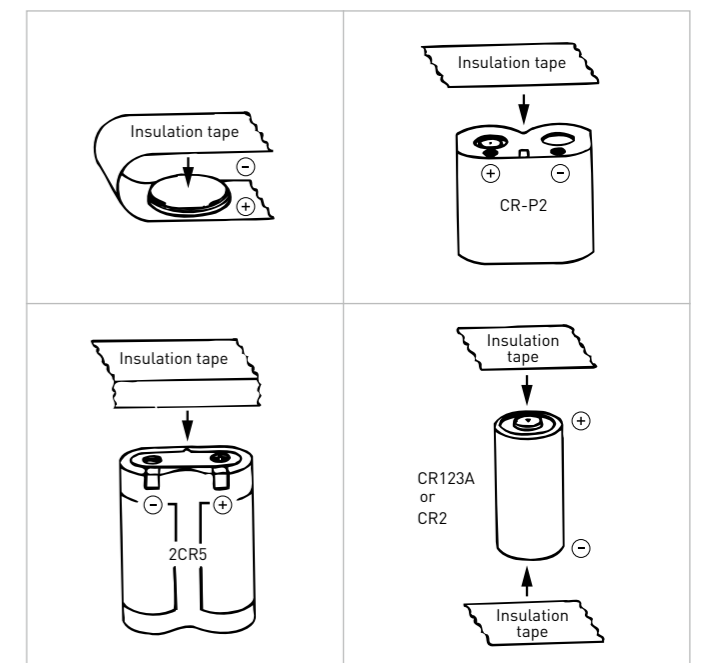

The data in this document are for descriptive purposes only and are not intended to make or imply any guarantee or warranty.
*1 Discharge circuits will be made by the contact of batteries, which may cause heating, rupture, or ignition of batteries.



LITHIUM & MICRO BATTERIES: TYPES AND FEATURES

Ever since Panasonic became the first company in the world to develop and commence the mass production of Lithium batteries for consumer products in 1971, Panasonic has launched a series of Lithium batteries in many shapes and sizes including cylindrical types, coin types and pin types. Panasonic has also successfully introduced coin type rechargeable Lithium batteries to the market for applications such as memory back-up or watches.

Today, Lithium batteries have a proven track record of opening up a host of new fields where conventional batteries cannot be used. Applications range from high-current discharge applications typified by 35 mm cameras to ultra-low current discharge applications in such products as electronic watches or applications as power supplies for IC memory back-up which require long-term reliability.

Panasonic has conducted repeated tests on the various safety and performance characteristics, plus the effects of environmental factors such as temperature. We have accumulated a wealth of corroborative data on the performance of our batteries which cannot be pinpointed by short-term accelerated tests. As a result, Panasonic batteries have won approval under the UL safety standards in the United States and wide recognition throughout the world for their high reliability and safety.

COMPARISON OF LITHIUM PRIMARY CHEMISTRY*1

Chemistry		BR	CR	ER	
Material	Cathode	CF	MnO ₂	SOCl ₂	
	Anode	Li metal	Li metal	Li metal	
	Electrolyte	Organic electrolyte	Organic electrolyte	Organic electrolyte	
Performance	Nominal voltage	3V	3V	3.6V	
	Discharge capacity		+	+	+
		Voltage during discharge (Initial)	Low current	+	+
	High current		+	++	-
	Voltage during discharge (End of capacity)	Low current	++	+	++
		High current	+	++	-
	Pulse performance at low temperature	Initial	+	++	-
		End of life	++	+	-
	Storage performance		++	+	++*2
	Reliability		++	+	-*2
Safety		++	++	-	
Environment	Eco friendly	++	++	-*3	

++ Very good capability
 + Good capability
 - Not good capability

TYPES OF LITHIUM & MICRO BATTERIES

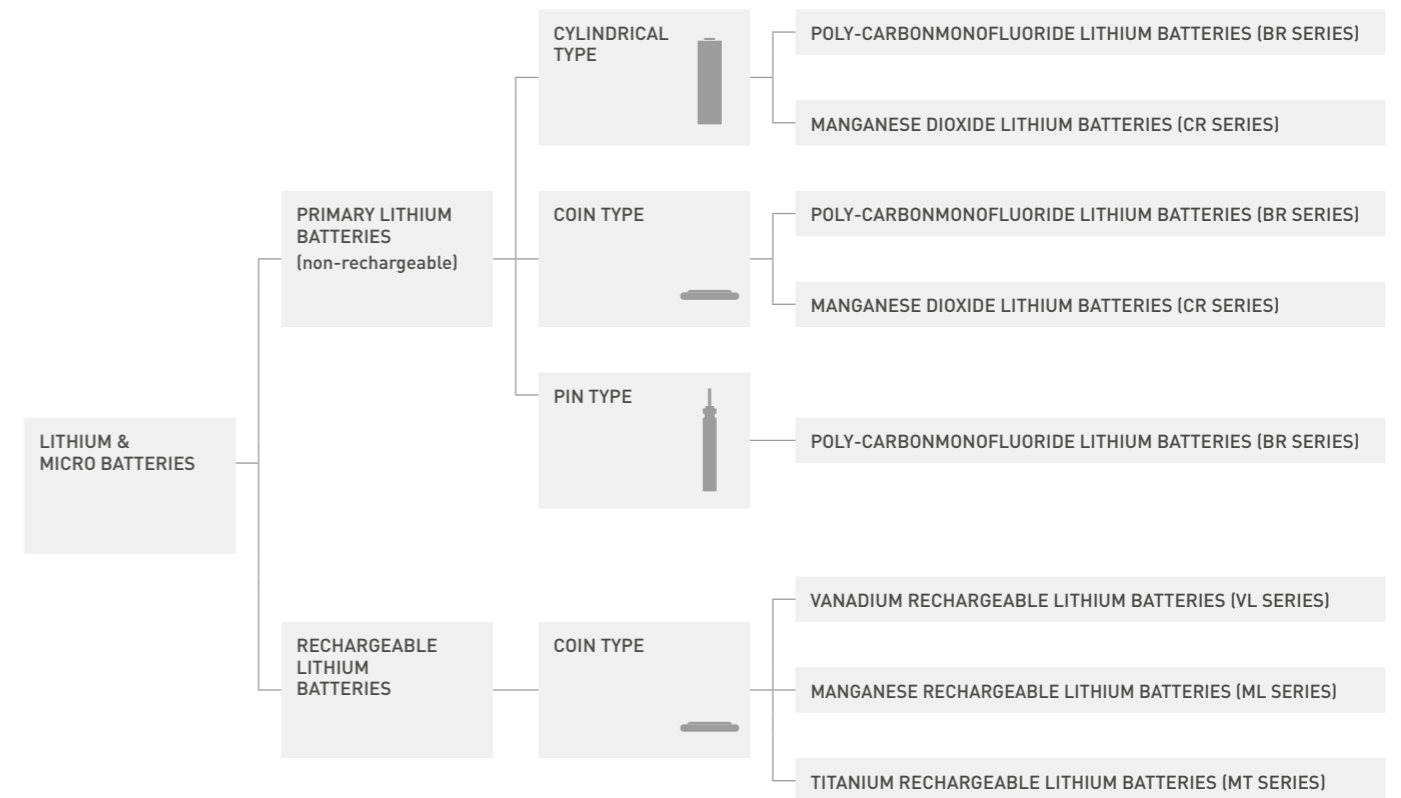

The data in this document are for descriptive purposes only and are not intended to make or imply any guarantee or warranty.

*1 Please contact Panasonic to get more detailed information about this technical comparison overview.

*2 Impedance is increasing due to the passivation phenomena.

*3 Harmful substances included.

High voltage

The high energy density of Lithium batteries and their high voltage of 3V (there are 1.5V and 2V lineups also) make them ideally suited for use in all kinds of products where the trend is to achieve increasing miniaturization. A single Lithium battery can replace two, three or more conventional batteries. The figure on the right shows the number of cells required to provide the C-MOS IC data holding voltage for each type of battery.

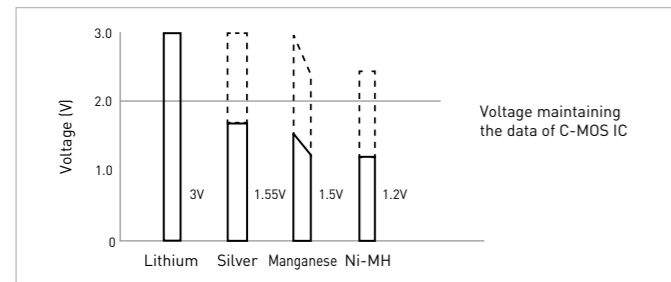

Low selfdischarge rate and superior storability

Since the substance that is chemically very stable is used for plus terminal as an active material (BR series: Poly-Carbon-monofluoride, CR series: Manganese Dioxide), if preservation conditions are proper, 90% of capacity remains even after ten years storage.

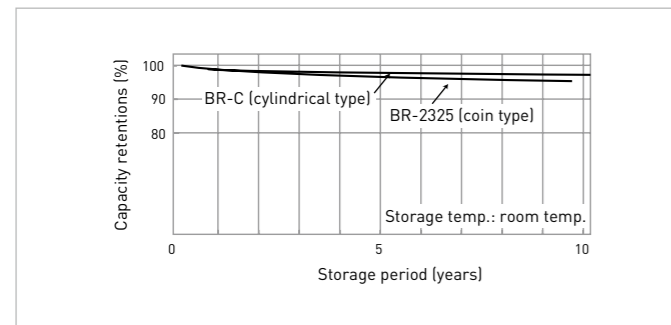

BR-2330A

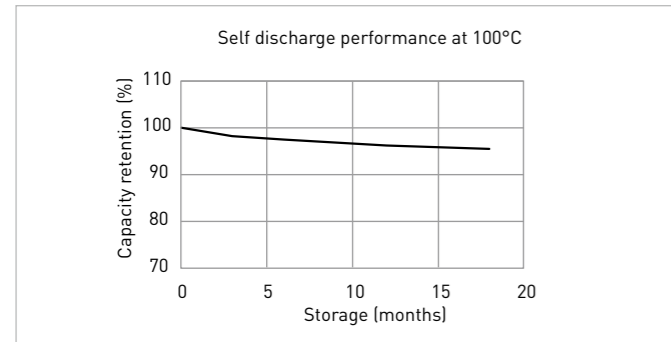

Long-term discharge

Long-term discharge has been verified at all operating temperatures under low-load discharge conditions.

BR-2/3A

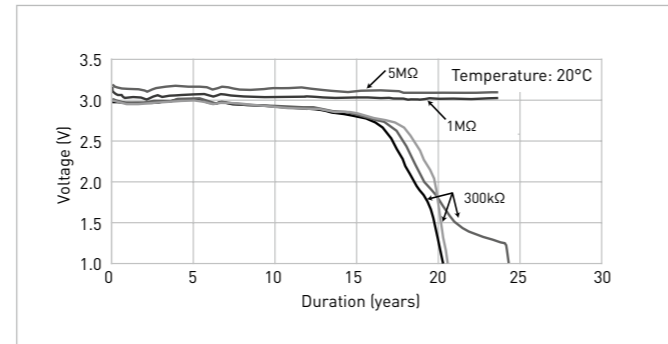

BR-2325

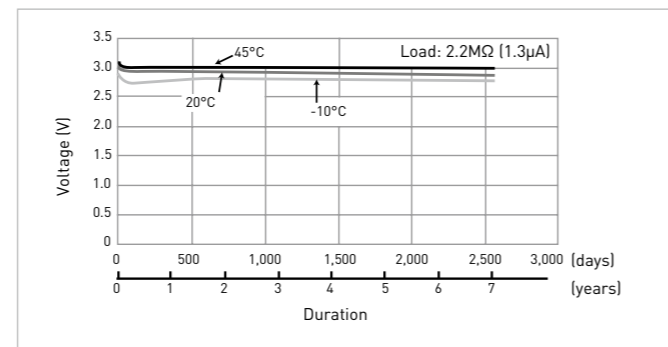

BR-C

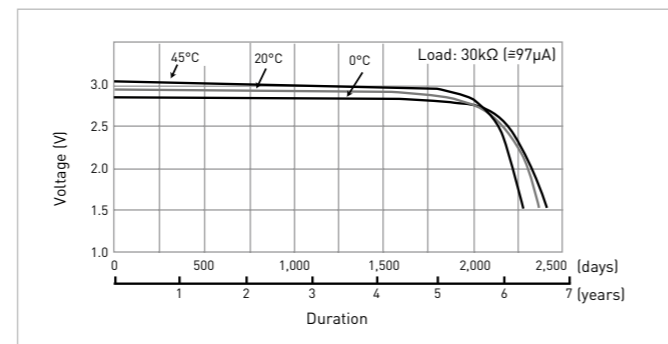

Outstanding electrolyte leakage resistance

Lithium batteries employ organic electrolytes with minimum creeping so they are vastly superior in terms of leakage resistance under environmental changes compared to other types of batteries that employ aqueous solution electrolytes. The batteries achieve stable characteristics under high temperature and humidity conditions (45°C/90% RH, 60°C/90% RH), and even under heat shock which constitutes the severest challenge for batteries.

Wide operating temperature range

Due to the use of organic electrolytes with a solidifying point that is much lower than the aqueous solution electrolytes used in other types of batteries, Lithium batteries are capable

of operation in a wide range of temperatures. Not only do the high operating temperature BR series cells use a special engineering plastic as the material for the gasket and separator instead of the conventional polyolefin resin but its operating temperature range has also been significantly increased by employing an electrolyte with a high boiling point.

Superior safety

Lithium batteries feature stable substances for the active materials and a structural design that assures safety and, as such, their superior safety has been verified from the results of repeatedly subjecting them to a number of different safety tests. As a result, Panasonic's Lithium batteries have been approved under the safety standard (UL1642) of UL (Underwriters Laboratories Inc.).

Battery surface temperature when short-circuited

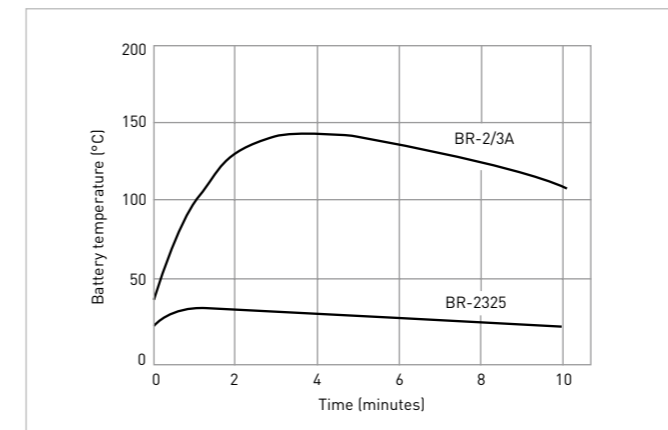

Leakage resistance test results

Model number	Conditions Storage	60°C		45°C/90%		60°C/90%		Temp. cycle 60 cycles	Heat shock 120 cycles
		1 month	3 months	1 month	3 months	1 month	3 months		
BR-2325		○	○	○	○	○	○	○	○
BR-2/3A		○	○	○	○	○	○	○	○

Leakage resistance evaluation items	Test conditions
High temperature storage	60°C
High temperature	45°C/90% RH
High humidity storage	60°C/90% RH
Temperature cycle	
Heat shock	

BR-2325 Operating voltage under high-resistance discharge

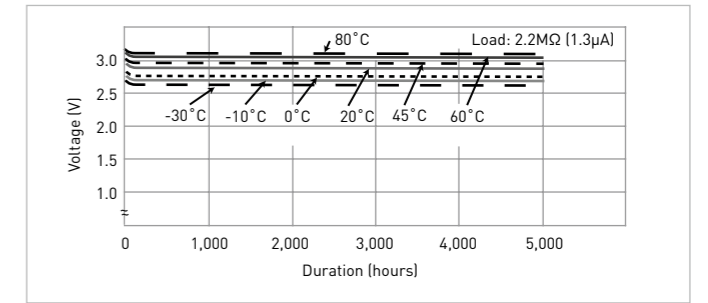

BR-2/3A Current drain vs. operation voltage

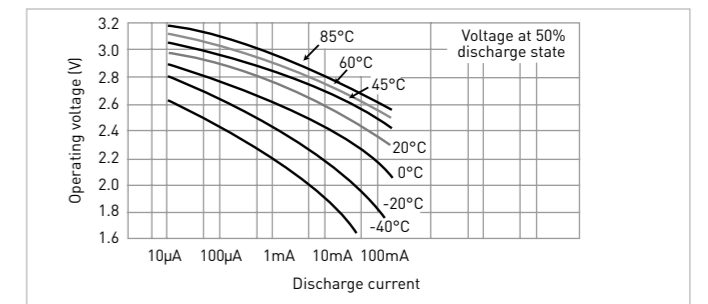

BR-2325 Charge resistance (10V consistent-voltage charge)

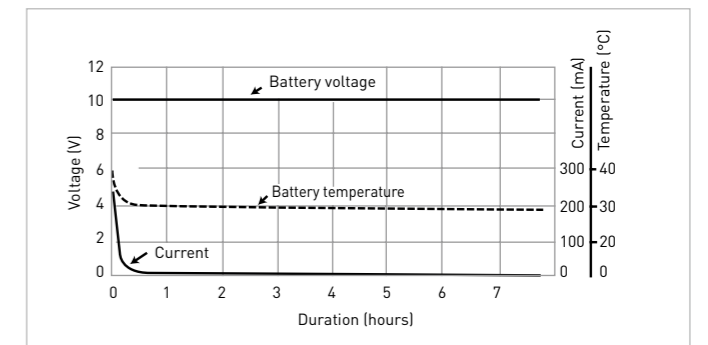

VL Charge characteristics

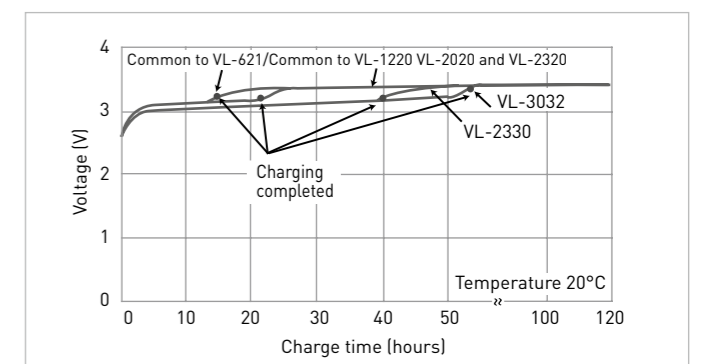

COIN TYPE RECHARGEABLE LITHIUM BATTERIES

Rechargeable Lithium batteries come with excellent characteristics and high reliability.

- ⦿ Long-term reliability
- ⦿ High capacity
- ⦿ Low self-discharge rate
- ⦿ Resistance to continuous discharge
- ⦿ Resistance to over discharge

Comparison table of Lithium battery types

Item	Type	Primary battery		Rechargeable battery		
	Model	BR	CR	VL	ML	MT
Material	⊕ electrode	(CF)n	MnO ₂	V ₂ O ₅	LixMnOy	LixOy
	⊖ electrode	Li	Li	LiAl	LiAl	LixTiOy
Nominal voltage [V]		3.0	3.0	3.0	3.0	1.5
Operating temperature range [°C]	Cylindrical type	Cylindrical: -40 to +85	Cylindrical: -40 to +70			
	Coin type	Coin: -30 to +80	Coin: -30 to +60			
	High operating temperature coin:	High operating temperature coin: -40 to +125		-20 to +60	-20 to +60	-10 to +60
Self-discharge (per year) under standard conditions	Cylindrical type	0.5%	1.0%	2.0%	2.0%	2.0%
	Coin type	1.0%	1.0%			
Average discharge voltage [V]		-	-	2.85	2.5	1.2
Charge voltage [V]		-	-	3.25 to 3.55	2.8 to 3.2	1.6 to 2.6
Cut off voltage [V]		2.0	2.0	2.5	2.0	1.0
Charge-discharge cycles		-	-	1,000 charge/discharge partly (charge/discharge for 10% of discharge depth)	1,000 charge/discharge partly (charge/discharge for 10% of discharge depth)	500 charge/discharge up to 1V or discharge limit voltage (charge/discharge for 100% of discharge depth)

Comparison between BR and CR

Model	BR vs. CR	
Performance	Discharge capacity	BR = CR
	Voltage during discharging	BR < CR (Higher)
	Flatness of discharge voltage	(Flatter) BR > CR
	Load characteristics	BR < CR (Superior)
	Storage properties (self-discharge) < 60°C > 60°C	(Less self-discharge) BR ≥ CR (Less self-discharge & stable) BR > CR

Notes: In terms of their characteristics, the CR series provides a slightly higher voltage during discharge than the BR series. BR batteries, compared with CR batteries, show more stable characteristics with less discharge voltage variations. These characteristics should be taken into consideration when selecting a battery for each application.

Primary type

Industry	Application	Coin type			Cylindrical type		Pin type	
		BR series	BR-A series	CR series	BR series	CR series for consumer	CR series for professionals	BR series
Auto-motive	Electronic Toll Collection (ETC)		○		⦿		⦿	
	Emergency call (E-Call)				○	○	⦿	
	Remote Keyless Entry (RKE)			⦿				
	Tyre Pressure Monitoring System (TPMS)		⦿					
Commu-nication	Advertising beacon					⦿		
	Fax machine	○		⦿				
	Personal digital assistant			⦿				
Home appliance	Sanitary equipment					⦿		
Marine	Emergency position indicating radio beacon			○	○	○	⦿	
	Life jacket light			○	○	○	⦿	
Medical	Digital thermometer	○		⦿				
	Scales			⦿				
Metering	Distance meter					○		○
	Electricity meter	⦿		○				
	Heat cost allocator		⦿		⦿			
	Water meter	⦿			⦿		⦿	
Security	Door lock system			⦿		⦿		
	Smoke detector				○		⦿	
	Window monitoring system			⦿	○	⦿		
Others	Fishing equipment							⦿
	Real Time Clock (RTC)	⦿		○	⦿			
	Tracking & RFID	○		⦿	○		○	
	Vending machine			⦿				
	Watch			⦿				

Rechargeable type

Industry	Application	Coin type		
		VL series	ML series	MT series
Auto-motive	Remote Keyless Entry (RKE)	⦿	○	
Commu-nication	Fax machine	⦿	○	
Others	Calculator	○	○	
	Real Time Clock (RTC)	○	⦿	
	Tracking & RFID	○	○	
	Vending machine	○	○	
	Watch			⦿

- ⦿ Recommended applications
- Potential applications

SELECTING A BATTERY

The steps for selecting the batteries for the power supplies of specific equipment are summarized below.

Preparation of required specifications (draft)

The required specifications (draft) are studied by checking the requirements for the batteries to be used as the power supplies of the specific equipment and their conditions against the battery selection standards. The technical requirements for battery selection are shown in the table below for reference purposes.

Selection of a battery

Select several candidate batteries by referring to the catalogs and data sheets of batteries which are currently manufactured and marketed. From this short list, select the battery which will best meet the ideal level of the requirements. In actual practice, however, the 'perfect' battery is seldom found by this method, instead, the basic procedure followed should be to examine the possibility of finding a compromise or partial compromise with the required specifications (draft) and then make a selection under the revised requirements from the batteries currently manufactured and marketed. Such a procedure enables batteries to be selected more economically. Questions and queries arising at this stage should be directed to our battery engineers. Sometimes, although it may not be shown in the catalog, the appropriate battery has become available through recent development or improvement. As a rule, the required specifications are finalized at this stage.

Requests for developing or improving batteries

If the battery that meets the essential and specific requirements cannot be found through the selection process described above, a request for battery development or improvement should be made to our technical department. A request like this should be coordinated as early as possible to allow for a sufficient study period. While this period depends on the nature of the request and the difficulties involved, a lead time of at least 6 to 12 months is usually required.

MODEL NUMBER

How to interpret the model numbers generally used for coin type Lithium batteries

The model numbers are normally indicated using two upper-case English letters and a figure consisting of three or more digits as shown in the example below. This numbering system is supported by the Japan International Standard Committee of Clocks and Watches and is also an established practice in Japan.

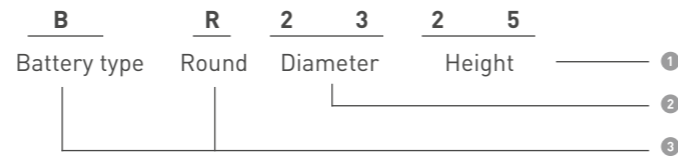

- ① Figures to first decimal place with decimal point omitted (ex. 2.5mm)
- ② Integers omitting fractions (ex. 23mm Dia.)
- ③ In accordance with JIS and IEC standards

Examples

B R - 1 / 2 A A

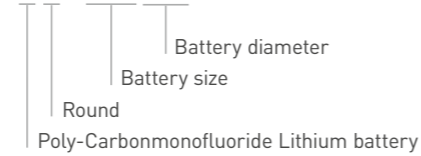

C R - 1 2 3 A

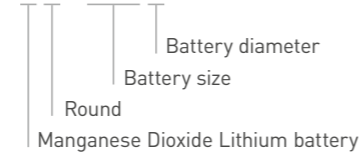

B R - 2 4 7 7 A

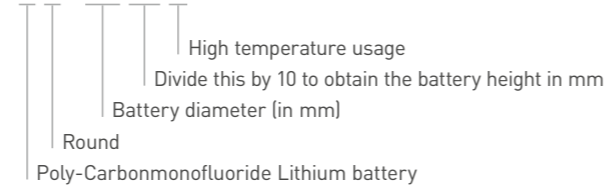

C R - 2 0 3 2

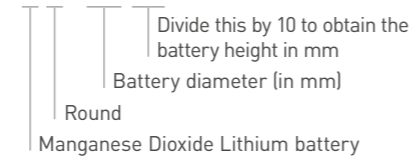

V L - 2 0 2 0

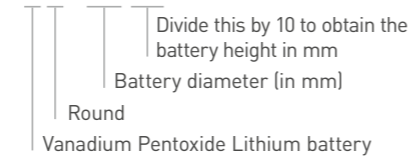

TECHNICAL CONDITIONS FOR SELECTING BATTERIES

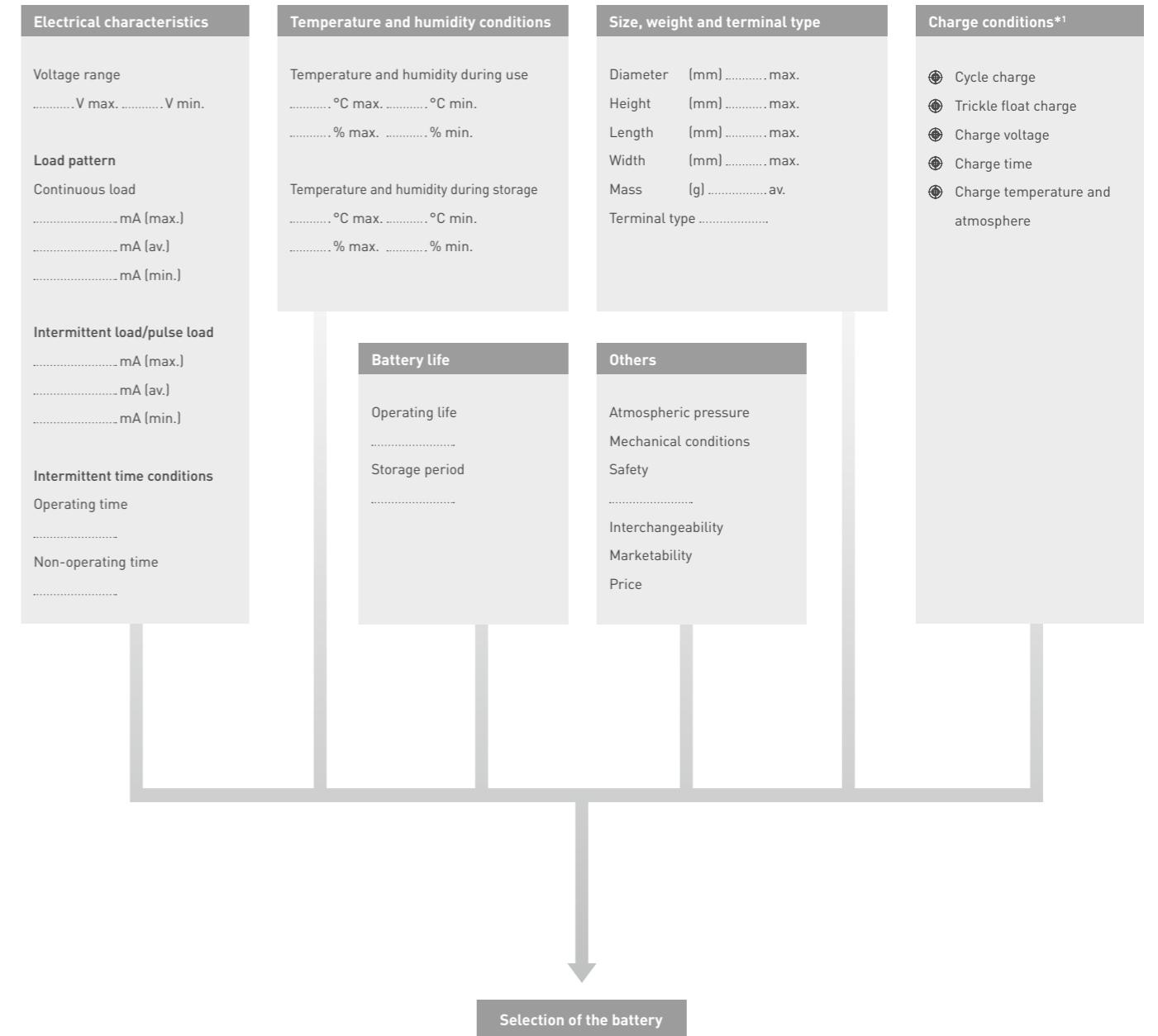

COIN TYPE PRIMARY LITHIUM BATTERIES (EXAMPLE)

Discharge life as a function of operating current

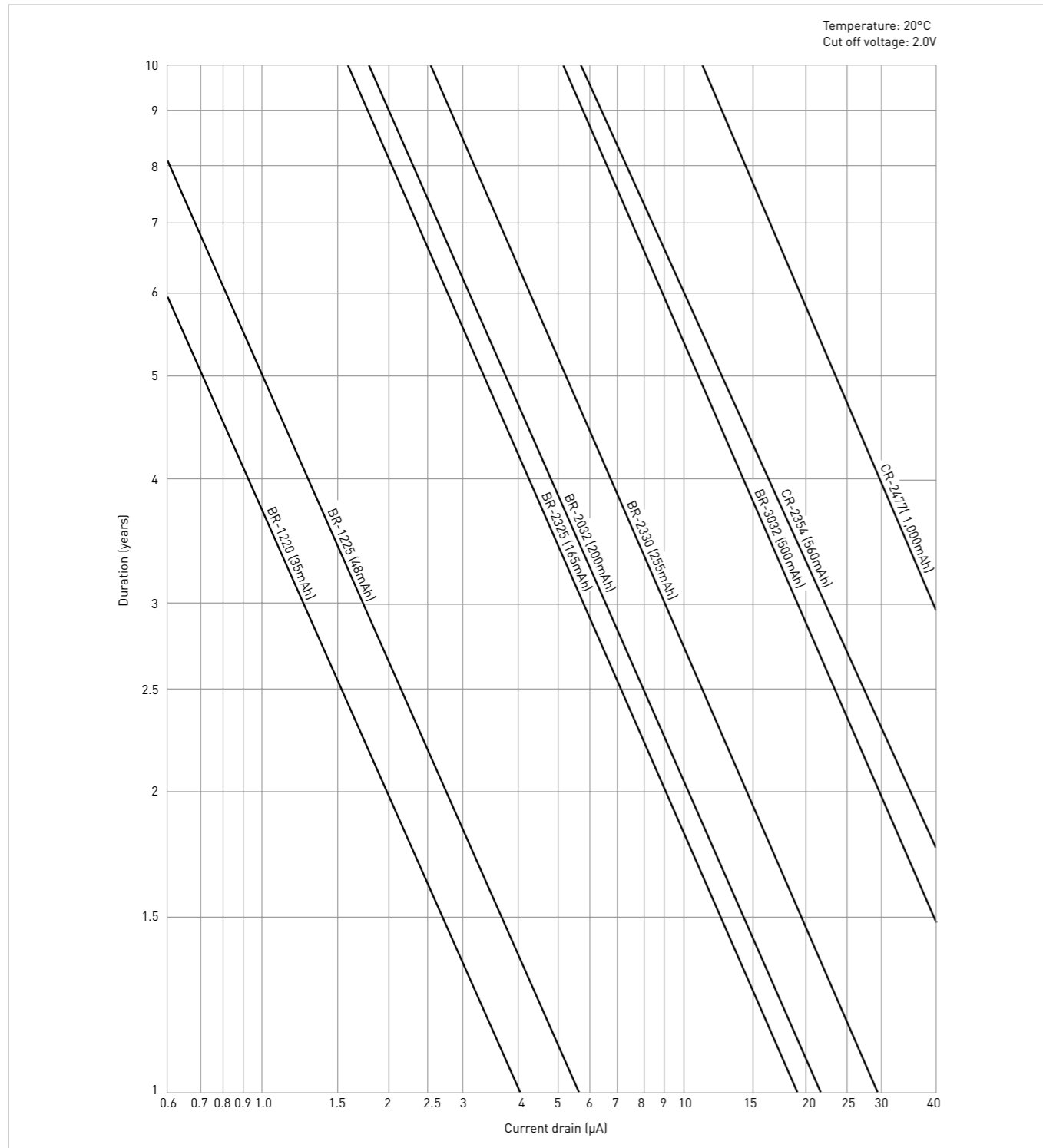

General formula (rough value with 20°C, standard load)

Calculation Duration (years) = $\frac{\text{Nominal capacity (mAh)}}{\text{Current drain (mA)} \times 24 \text{ (hours)} \times 365 \text{ (days)}}$

Self Discharge

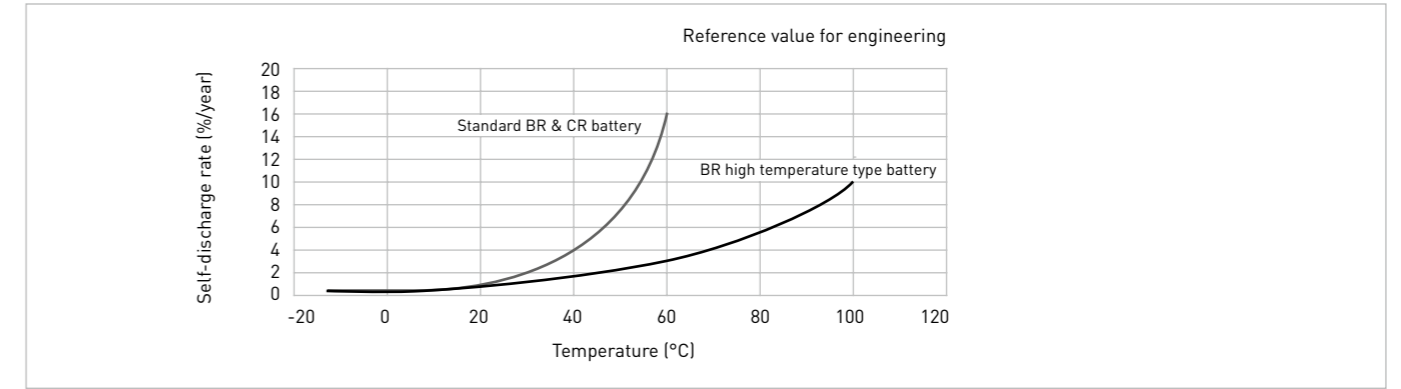

CYLINDRICAL TYPE PRIMARY LITHIUM BATTERIES (EXAMPLE)

Discharge life as a function of operating current

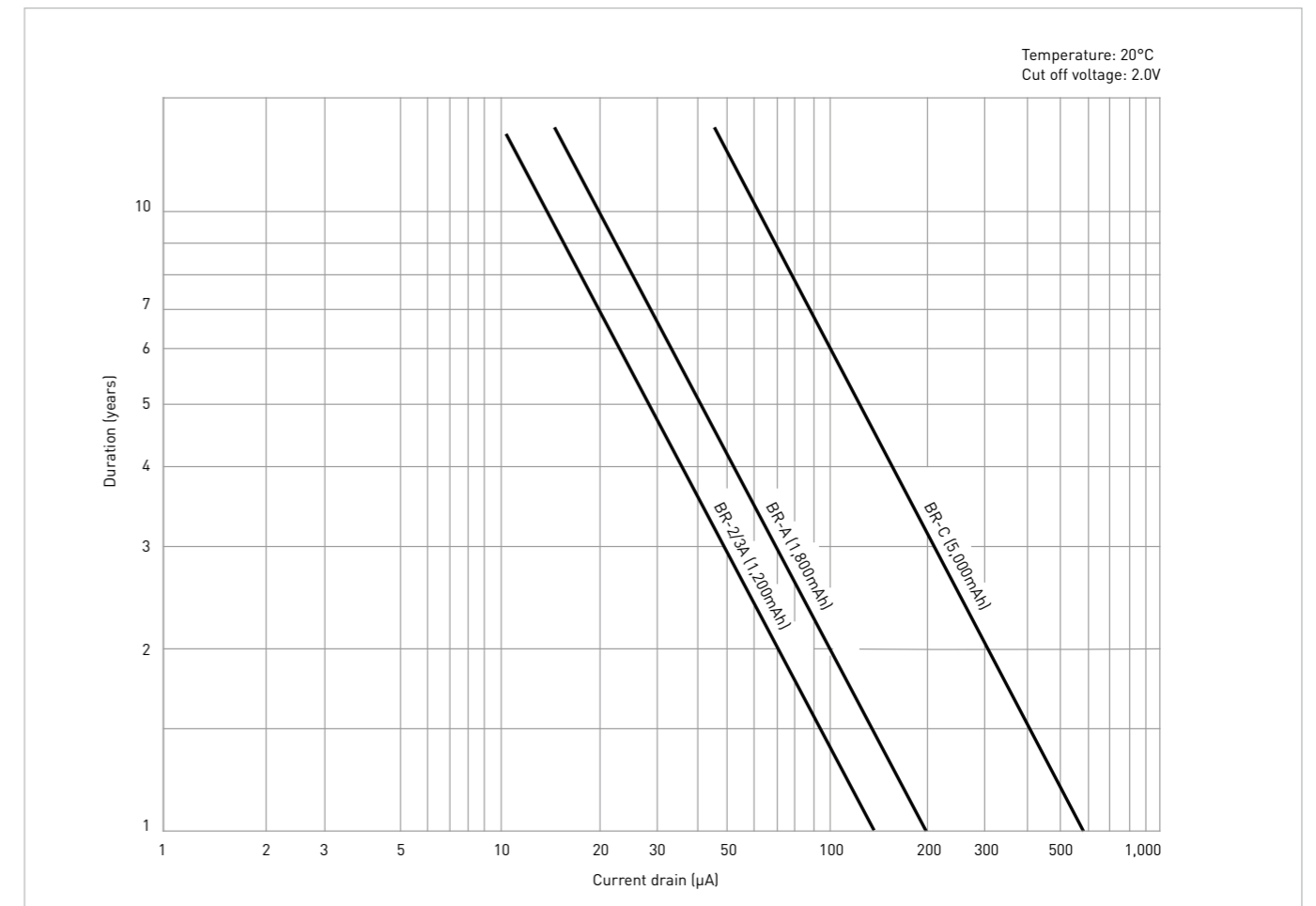

General formula (rough value with 20°C, standard load)

Calculation Duration (years) = $\frac{\text{Nominal capacity (mAh)}}{\text{Current drain (mA)} \times 24 \text{ (hours)} \times 365 \text{ (days)}}$

Self Discharge

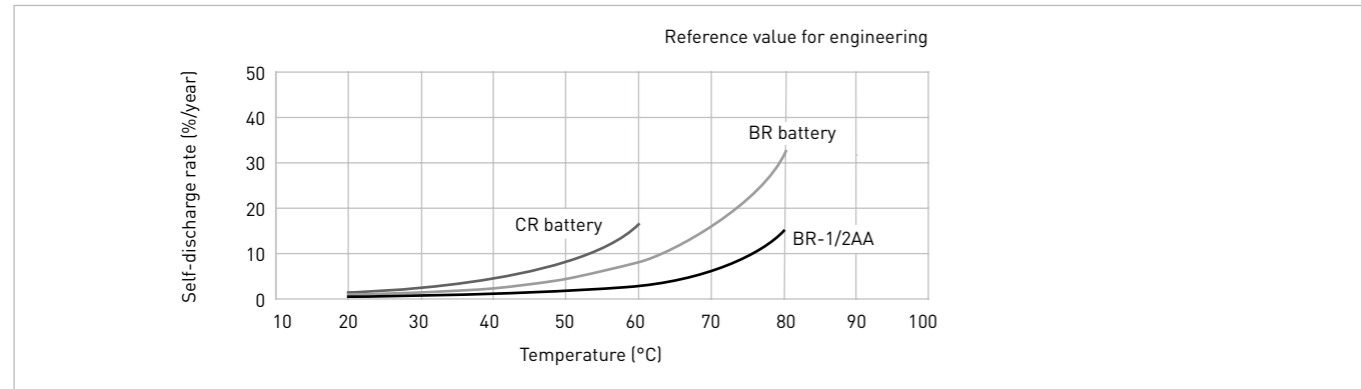

COIN TYPE RECHARGEABLE LITHIUM BATTERIES (EXAMPLE)

Discharge life as a function of operating current

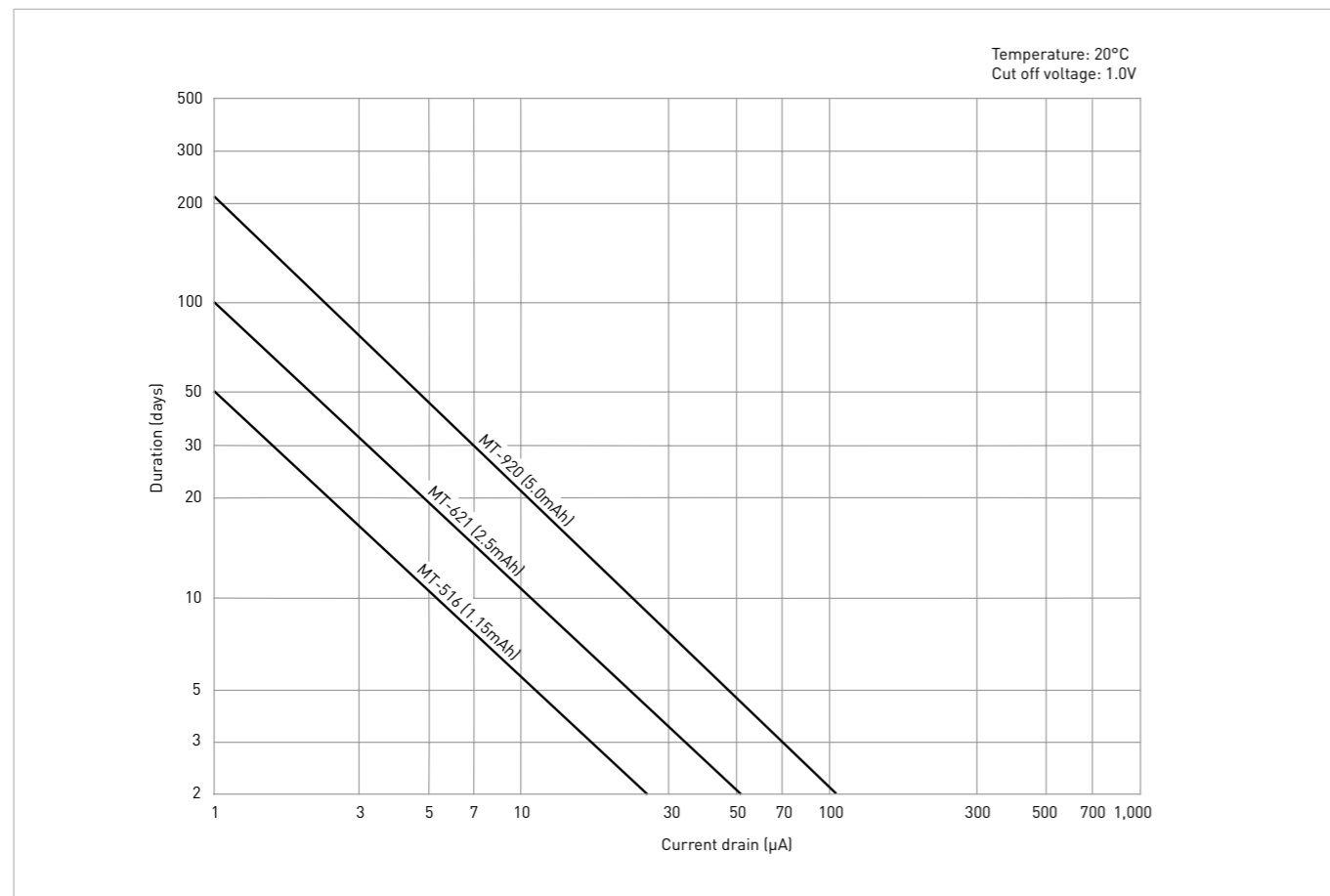

Discharge life as a function of operating current

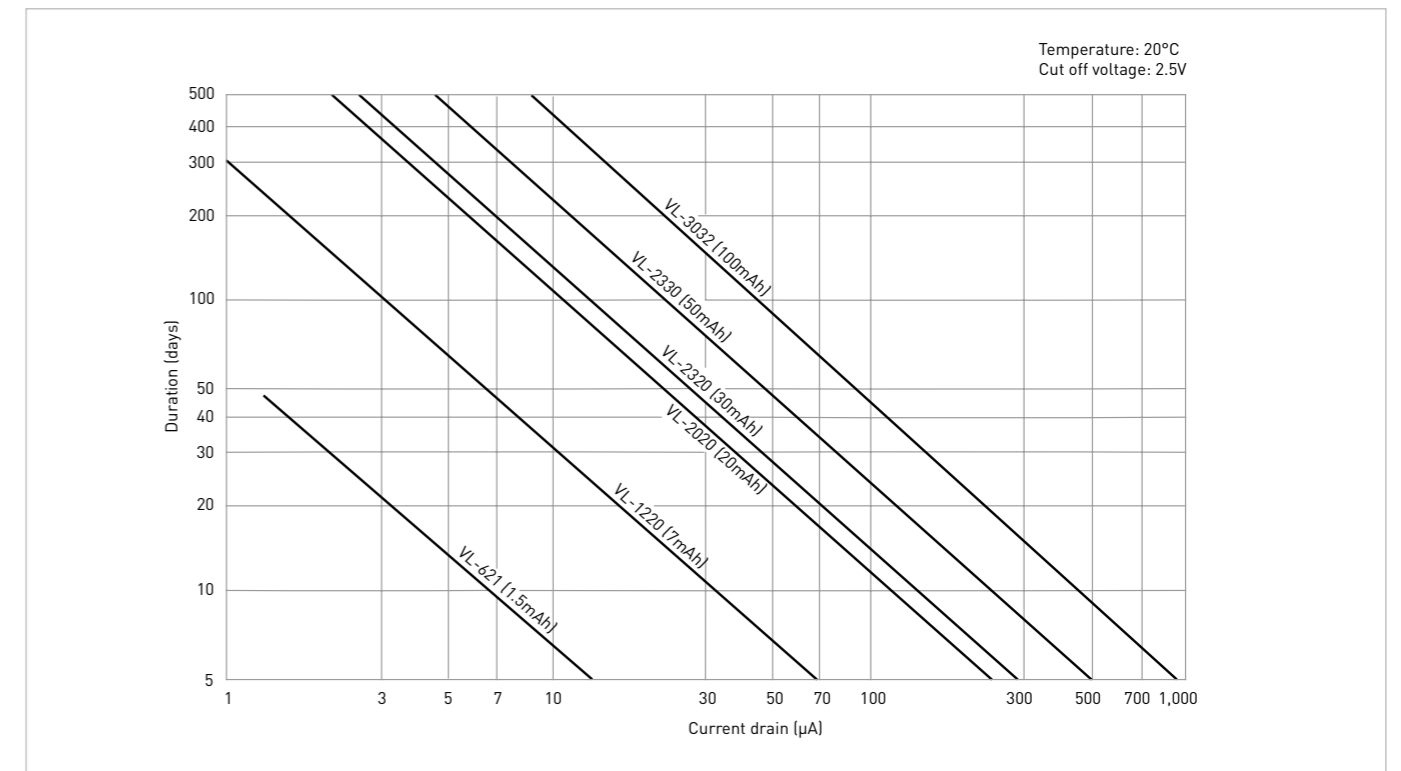

Cycle life

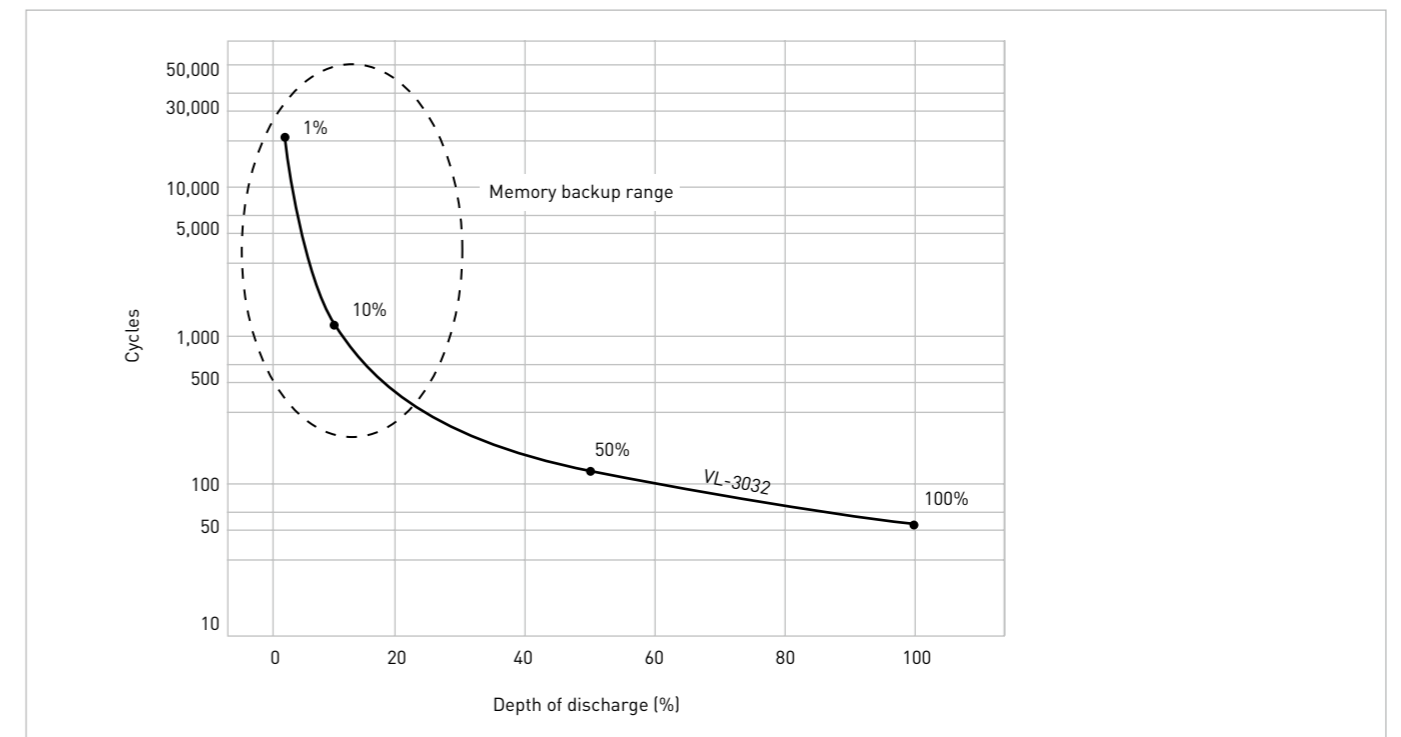

The number of cycles is defined with the batteries' remaining capacity $\geq 50\%$.

CHARGE RETENTION AND TEMPERATURE DEGRADATION DEPENDENCIES

VL/ML residual capacity and recovery

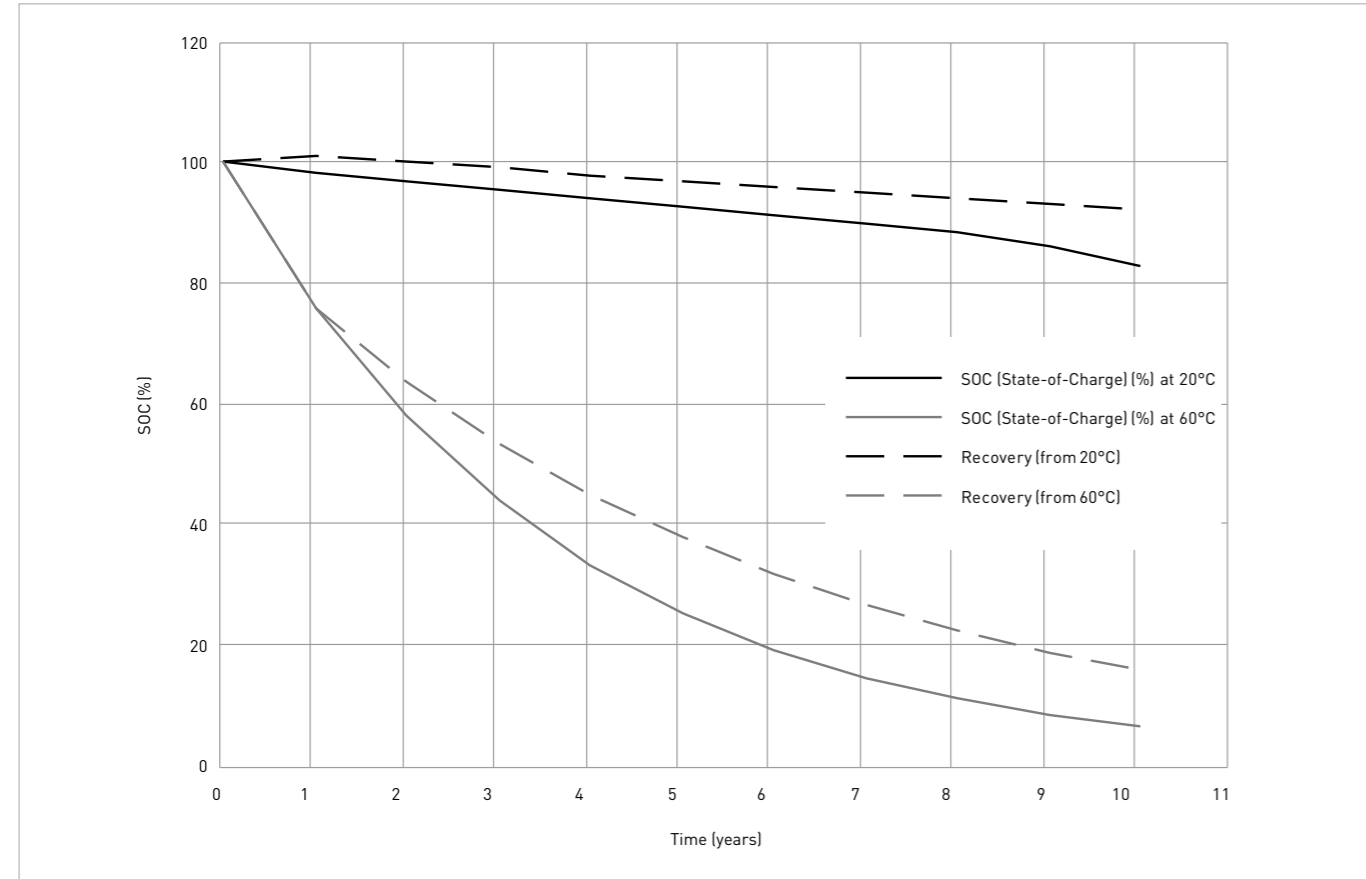

VL/ML capacity degradation under float

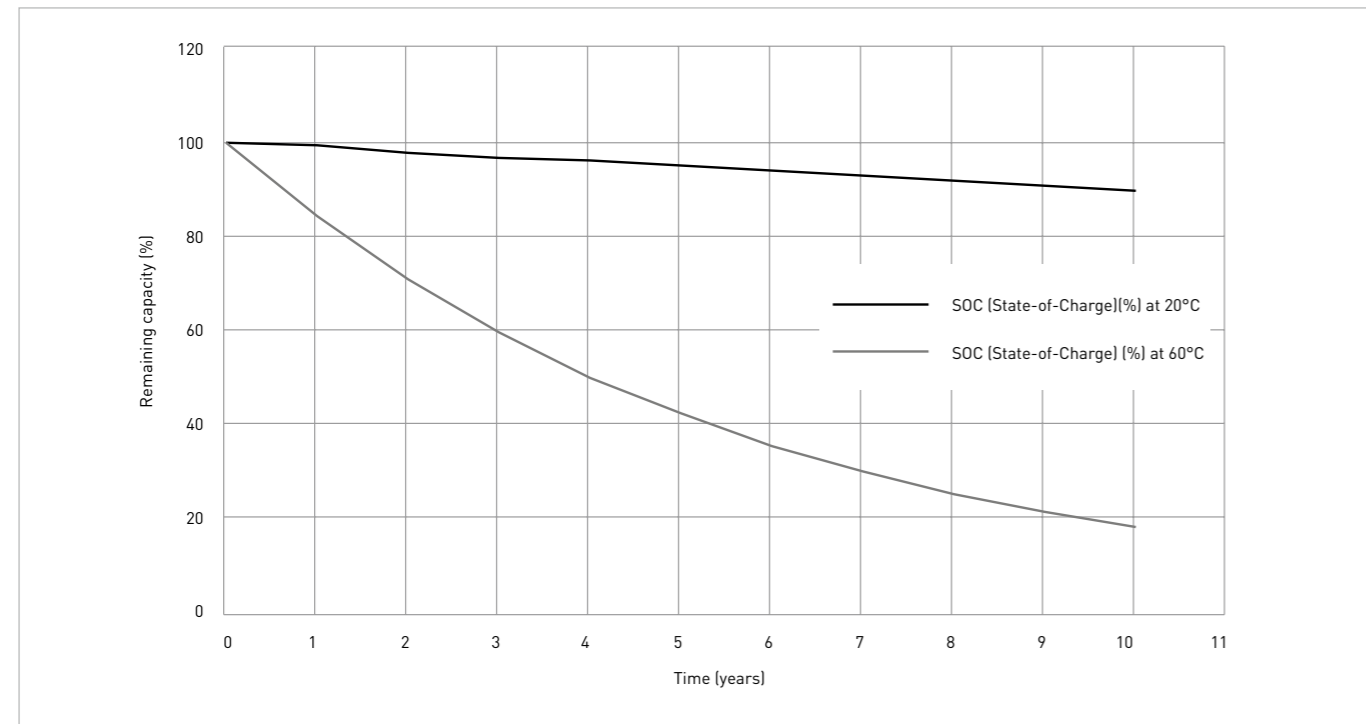

APPLICABLE BOTH PRIMARY AND RECHARGEABLE BATTERIES

Classification	Item	Precaution
Batteries	Voltage measurement	To measure the battery voltage, use an instrument with an input resistance of 10MΩ or higher.
	Internal resistance measurement	To measure the internal resistance, use a 1,000Hz AC instrument.
	Electrical characteristics check	Even minimal shorting causes the battery voltage to drop, requiring a period of time for the voltage to recover. Checking the voltage characteristics before the voltage has sufficiently recovered in such a situation may result in a misjudgment of battery voltage.
	Cleaning	Prior to installation in the equipment, wipe the batteries and equipment terminals clean using a dry cloth, etc.
	Washing and drying	<ul style="list-style-type: none"> Washing: Use of a conductive detergent causes batteries to discharge, the battery voltage to drop and the battery performance to deteriorate in other ways. Be sure to use a non-conductive detergent. Drying: The heat produced when the temperature of the battery units rises above 85°C deforms the gaskets and causes electrolyte leakage and a deterioration in performance. Be sure to dry batteries only for short periods of time at temperatures below 85°C.
	Mounting	<ul style="list-style-type: none"> Ensure that dust and other foreign substance will not cause shorting between the poles. When handling batteries, wear finger covers or gloves made of rubber, cotton, etc. to protect the batteries from dirt.
	UL	Strictly comply with the conditions outlined on the next page.
	Use of multiple batteries	Give sufficient consideration to safety in design when a multiple number of batteries are to be used. Consult with Panasonic concerning packs of multiple batteries.
	Simultaneous use of other types of batteries	When other types of batteries are also to be used in the some equipment, design the circuitry in such a way that the current (leakage current) from the other batteries will not flow to the Lithium batteries. (This applies to primary batteries.)
	Use of batteries in series or in parallel	This requires special circuitry: Please consult with Panasonic. Do not use Lithium batteries together with different types of batteries in series or in parallel.
Battery compartments in equipment	Battery life	Prior to installation in the equipment, wipe the batteries and equipment terminals clean using a dry cloth, etc.
	Design	<ul style="list-style-type: none"> Ensure that the batteries can be replaced easily and that they will not fall out of position. Give consideration to the battery dimensions, tolerances, etc. Give consideration to the shape of ⊕ and ⊖ electrodes of the batteries and their tolerances to prevent installation in reverse. Clearly indicate on the battery compartment the type of batteries to be used and their correct installation direction (polarities). Limit the electrical circuits inside the battery compartment only to the circuits relating to the battery contacts. With the exception of the terminal areas, insulate the battery compartment from the electrical circuits. Take steps to minimize any damage to the equipment resulting from electrolyte leakage from the battery compartment. Batteries should be free from leakage of liquids, which can damage equipment and spoil the contact at terminals, making the operation of equipment unstable.
	Battery layout and construction and materials of compartment	<ul style="list-style-type: none"> Take steps to ensure the batteries are not located heat generating component in the equipment. Installing batteries near a heat source will heat up the batteries, causing thermal deformation of the gasket and resulting in electrolyte leakage and a deterioration in characteristics. Adopt a construction which allows the gases to be vented. Give consideration to the impact and the effect on the environment in selecting the materials to be used.
Contacts and connection terminals	Contact point materials	Use nickel-plated iron or nickel-plated stainless steel for the contact points.
	Contact pressure of contacts	In order to ensure stable contact, use the following levels of contact as a general guideline: 5N to 15N for cylindrical types 2N to 10N for coin types.
	Shape of terminals	Use of Y-shaped terminals (2-point contact) for both the ⊕ and ⊖ electrodes yield stable contact.
	Connection terminals	If lead wires and connection terminals such as tab terminals are required for the batteries, consult with Panasonic since we offer a range of external terminals (connectors, etc.).

Classification	Item	Precaution
Notes	Circuit design	<p>1. Shorting causes the battery voltage to drop to about 0V before slowly recovering from the open state. It takes time for the initial voltage to be restored. Notice that measuring the open-circuit voltage immediately after shorting may lead to a misjudgment that the battery is abnormal. The figure on the right illustrates how voltage recovers after shorting.</p> <p>2. Reverse current preventing diodes. Since Lithium primary batteries are not rechargeable, use of a reverse current preventing diode and a protective resistor in series is required where there is the possibility of charging in the equipment circuit. Use a silicon diode or Schottky diode with a low reverse current as the reverse current preventing diode. To maintain the characteristics of a coin type Lithium battery, the total charging amount of the battery during its total usage period must be kept within 3% of the nominal capacity of the battery.</p>

PRIMARY BATTERIES

Since Lithium primary batteries are not rechargeable, use a reverse current blocking diode and a protective resistor in series where there is the possibility of charging in the equipment circuit.

Reverse current blocking diode

Diode used

Use a low leak current diode (this current varies with temperature).

Selection standard

The total allowable charging amount of a battery during its total usage period must not be greater than 3% of the nominal capacity of the battery for a coin type battery or 1% for a cylindrical battery.

Example

When a CR-2477 (1,000mAh) coin type battery is to be used for 5 years, a reverse current preventing diode with a reverse current of 0.7μA or less is required.

Calculation method

$$1,000\text{mAh (CR-2477)} \times \leq 3\% \text{ (coin type battery)} = \leq 30\text{mAh}$$

$$30\text{mAh} \div \text{usage period (5 years} \times 365 \text{ days} \times 24 \text{ hours)} = 0.7\mu\text{A}$$

Use of protective resistor in series:

Selection and installation (UL Standard)

A resistor must be installed in series with the battery to limit the charge current which will flow to the battery in case of destruction in continuity of the reverse current preventing diode. The maximum allowable current is specified for each battery size in the table at the right, and the resistance value of the protective resistor is determined as:

$$R > V \div I$$

(where 'I' is the maximum allowable charge current specified by UL).

Conditions for UL Standard

(Contact Panasonic for further details.)

1. Use of protective resistor in series

Selection

Select the protective resistor in such a way that the charge current which will flow to the battery when the diode is destroyed is less than the value given in the table on the next page.

Installation

To protect the battery from being charged in the event of the destruction of the diode, install a protective resistor in series with the battery.

2. Battery replacement

Replacement by qualified engineer

These batteries are intended for use as a part of an electrical circuit in equipment and any battery with an asterisk '*' in the table on the next page should only be replaced by a qualified engineer.

Replacement by user

Those Lithium batteries which are not accompanied by an asterisk '*' in the table on the next page and which include the use of up to four of them in series or in parallel may be replaced by users provided that the conditions specified by the UL Standard are met.

Use in series or in parallel

In replacing up to four batteries, the batteries must all be replaced with new ones at the same time. Set the maximum allowable charge current to within the current permitted by the number of batteries in series or in parallel.

RECHARGEABLE BATTERIES

Use of multiple batteries

Consult with Panasonic if two or more Vanadium rechargeable Lithium batteries (VL series) or Manganese rechargeable Lithium batteries (ML series) are to be used in series or in parallel.

Charging

Details on the charge voltage, charge current and charge circuit are given for each type of battery.

Conditions of UL approval

The maximum charge current must be restricted to 300mA when protective components have been subjected to short- or open-circuiting.

PRIMARY AND RECHARGEABLE BATTERIES

UL approval and maximum allowable charge current

Shape	Model number	UL approval	Maximum abnormal charging current (mA)
Cylindrical type BR series	BR-1/2AA	●	5
	BR-2/3A	●	10
	BR-2/3AG	●	10
	BR-A*1	●	15
	BR-AG*1	●	15
	BR-C*1	●	20
Cylindrical type CR series	CR-2	●	20
	CR-123A	●	25
	2CR-5	●	25
	CR-P2	●	25
Cylindrical type CR series for industrial	CR-V3	●	25
	CR-2/3AZ	●	25
	CR-AG*1	●	25
Coin type BR series	BR-1220	●	3
	BR-1225	●	3
	BR-1632	●	4
	BR-2032	●	5
	BR-2325	●	5
	BR-2330	●	5
	BR-3032	●	5
Coin type BR-A series	BR-1225A	●	3
	BR-1632A	●	4
	BR-2330A*1	●	5
	BR-2450A*1	●	5
	BR-2477A*1	●	5
Coin type CR series	CR-1025	●	2
	CR-1216	●	3
	CR-1220	●	3
	CR-1612	●	3
	CR-1616	●	4
	CR-1620	●	4
	CR-1632	●	4
	CR-2012	●	10
	CR-2016	●	10
	CR-2025	●	10
	CR-2032	●	10
	CR-2330	●	10
	CR-2354	●	10
	CR-2412	●	10
	CR-2450	●	30
	CR-2477	●	10
	CR-3032	●	10
Pin type BR series	BR-425	●	0.1
	BR-435	●	0.2
Coin type VL series	VL-621*1	●	300
	VL-1220	●	300
	VL-2020	●	300
	VL-2320	●	300
	VL-2330	●	300
	VL-3032	●	300
Coin type ML series	ML-421	●	300
	ML-614	●	300
	ML-621	●	300
	ML-920	●	300
	ML-1220	●	300
	ML-2020*1	●	300
Coin type MT series	MT-516	●	300
	MT-621	●	300
	MT-920	●	300

● UL approval

Selecting batteries

When selecting batteries, give consideration to such factors as the current consumption of the equipment in which the batteries are to be used, the expected life of the batteries, and temperature in the operating environment. At low operating environment temperatures, the consumption current of the ICs drops but the discharge voltage of the batteries will also decrease. Also it is important to note that the capacity deterioration of batteries in long-term use becomes significant at high operating environment temperatures.

Memory back-up circuit and holding voltage

The circuit typically used for memory back-up is shown in the figure on the right. The memory holding voltage is expressed as: $V_B - V_F - I_F \times R >$ memory holding voltage of IC.

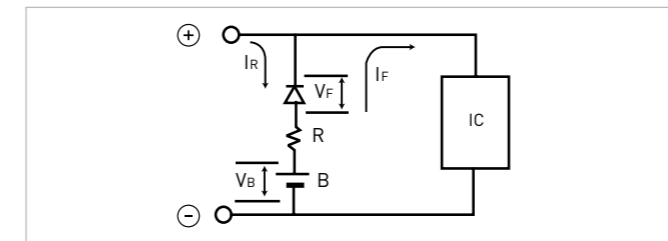

Reverse current blocking diode

Since Lithium primary batteries are not rechargeable, use of a reverse current blocking diode and a protective resistor in series is required where there is the possibility of charging in the equipment circuit. Use a diode with a low leak current as the reverse current blocking diode. To maintain the characteristics of a coin type Lithium battery, the total charging amount of the battery during its total usage period must be kept within 3% of the nominal capacity of the battery.

For example, assuming that a CR-2477 (1,000mAh) will be used in a memory back-up power supply for 5 years, charging by the leak current of the reverse current blocking diode should be no greater than 30mAh (= 3% of 1,000mAh), thus: 30mAh ÷ usage period (5 years x 365 days x 24 hours) = 0.7µA. In other words, a leak current blocking diode whose reverse current is not greater than 0.7µA must be selected.

Allowable total charging amount

- Within 3% for coin type batteries
- Within 1% for cylindrical type batteries

Note that the leak current of reverse current blocking diodes varies with temperature.

(A) 2-cell 6V usage

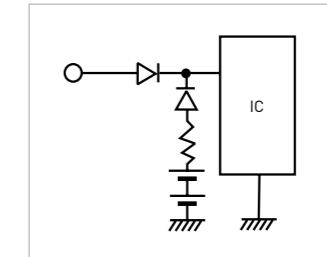

(B) Parallel usage

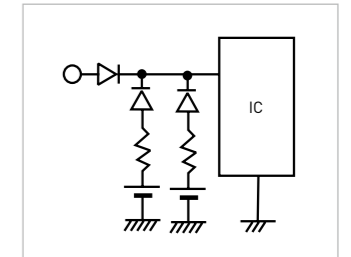

(C) UL conditions

(When a protective resistor has been inserted)

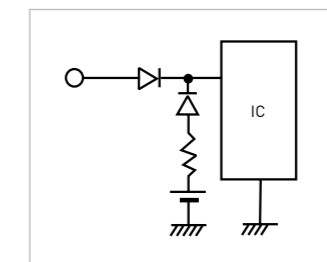

(D) UL conditions

(Protective diode)

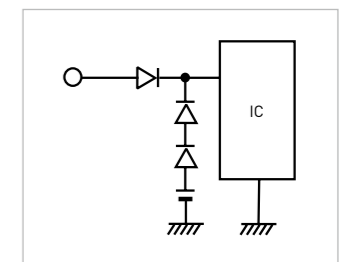

Charge test results assuming diode leakage current

BR-2/3A (cylindrical type) Charge test

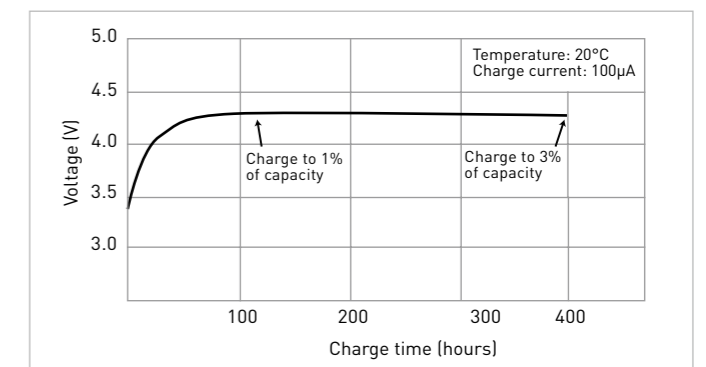

BR-2/3A (cylindrical type) Discharge test after charging

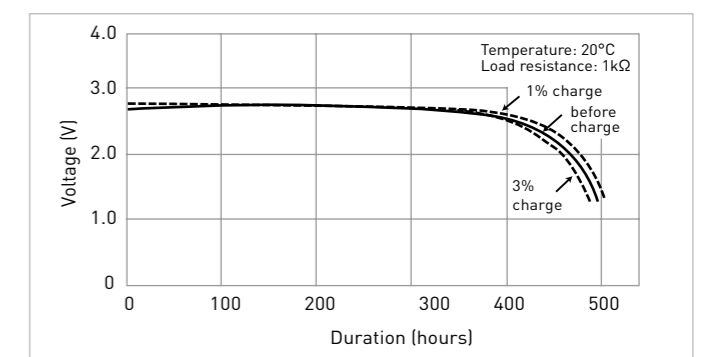

STATE-OF-THE-ART LITHIUM PRIMARY BATTERIES



VIDEO



Scan QR code to view product series video.

Lithium battery technologies are becoming increasingly important. Due to their high voltage, low self-discharge and proven reliability, they can power a broad range of sophisticated applications. Innovative Lithium technologies by Panasonic are extremely long-lasting under severe conditions (BR series) or feature top pulse currents (CR series) with a 3-volt voltage.



POLY-CARBONMONOFLUORIDE LITHIUM BATTERIES (BR SERIES) – CYLINDRICAL TYPE LITHIUM BATTERIES

Our Panasonic Poly-Carbonmonofluoride Lithium batteries (BR series) are ideal for applications such as meters or smoke detectors which demand either long-term power supply reliability or need to handle a wide temperature range.

FEATURES

- Operating temperature range: between -40°C ~ +85°C
- Self discharge rate at 20°C is just 0.5% per year
- Superior long-term reliability
- Years of experience in production

APPLICATIONS

- Heat cost allocators
- Water & gas meters
- Car alarm
- Smoke detectors
- Tracking & RFID
- Marine devices, etc.

Model number*1	Electrical characteristics at 20°C		Dimensions with tube (mm)		Approx. weight (g)	IEC
	Nominal voltage (V)	Nominal*2 capacity (mAh)	Diameter	Total height		
BR-1/2AA*3	3	1,000	14.5	25.5	8.0	-
BR-2/3A	3	1,200	17.0	33.5	13.5	BR17335
BR-2/3AG	3	1,450	17.0	33.5	13.5	BR17335
BR-A	3	1,800	17.0	45.5	18.0	-
BR-AG	3	2,200	17.0	45.5	18.0	-
BR-C	3	5,000	26.0	50.5	42.0	-

3D ILLUSTRATION*4

- 1 Positive pole
- 2 Gasket
- 3 Separator
- 4 Cathode (Carbonmonofluoride)
- 5 Anode (Lithium)
- 6 Insulator
- 7 Tube
- 8 Positive pole platform
- 9 Cell can
- 10 Collector
- 11 Negative pole



VIDEO



Scan QR code to view 3D animated video.

The data in this document are for descriptive purposes only and are not intended to make or imply any guarantee or warranty.

*1 G indicates higher capacity versions.

*2 Capacity based on standard drain and cut off voltage down to 2.0V or 4.0V at 20°C.

*3 Operating temperature range is from -40°C ~ +100°C.

*4 The illustration shows only one example of Lithium battery structure.

BR-1/2AA

DIMENSIONS (MM)

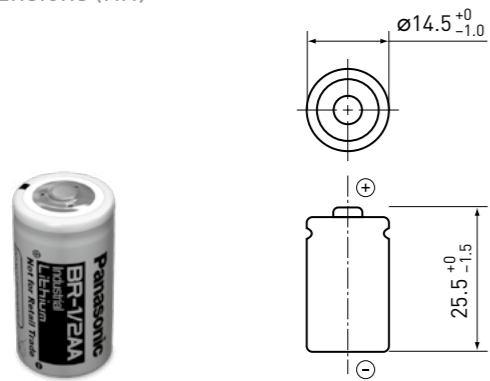

Model number	BR-1/2AA
Nominal voltage (V)	3
Nominal capacity (mAh)	1,000
Diameter (mm)	14.5
Total height (mm)	25.5
Discharging temperature range (°C)	-40 to +100
Weight (g)	8.0

DISCHARGE TEMPERATURE CHARACTERISTICS

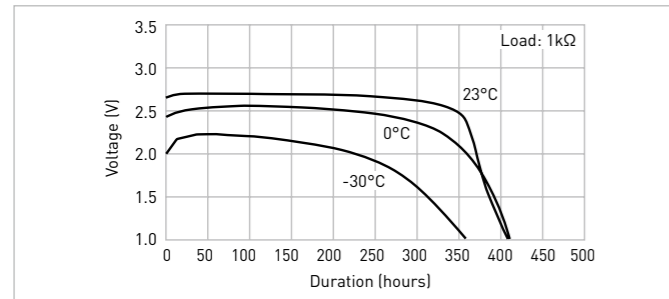

BR-2/3A

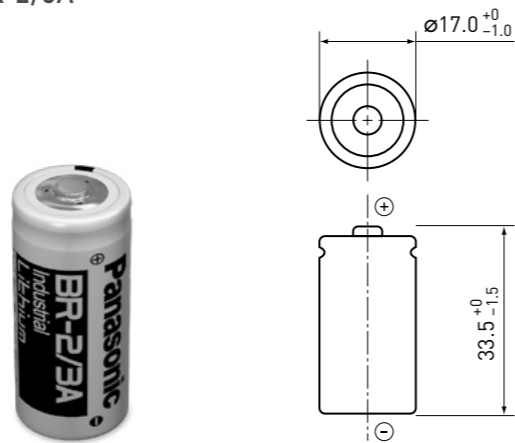

Model number	BR-2/3A
Nominal voltage (V)	3
Nominal capacity (mAh)	1,200
Diameter (mm)	17.0
Total height (mm)	33.5
Discharging temperature range (°C)	-40 to +85
Weight (g)	13.5

DISCHARGE TEMPERATURE CHARACTERISTICS

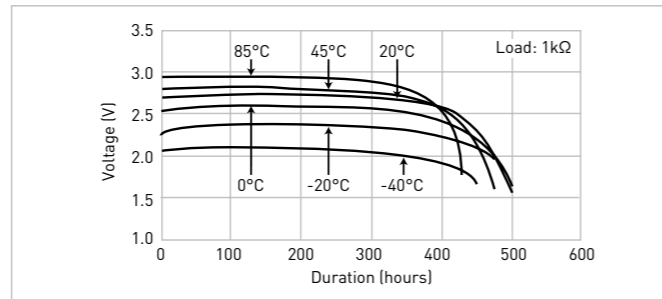

OPERATING VOLTAGE VS. DISCHARGE CURRENT*1

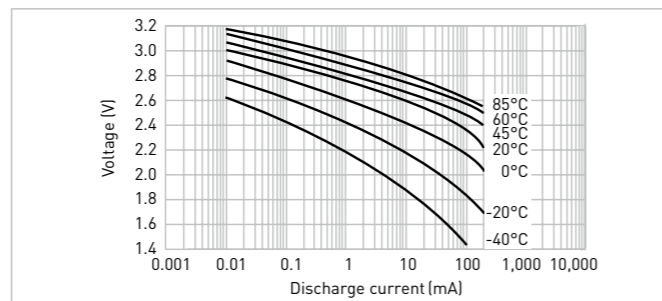

BR-2/3AG

DIMENSIONS (MM)

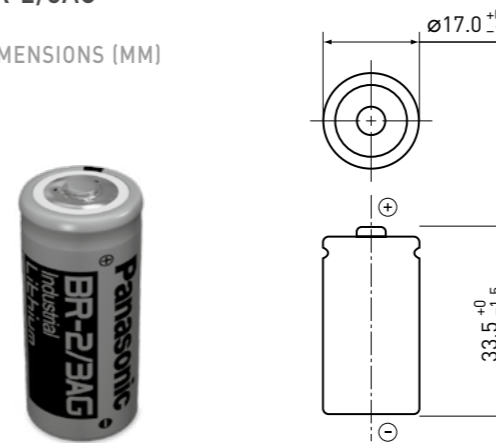

Model number	BR-2/3AG
Nominal voltage (V)	3
Nominal capacity (mAh)	1,450
Diameter (mm)	17.0
Total height (mm)	33.5
Discharging temperature range (°C)	-40 to +85
Weight (g)	13.5

DISCHARGE TEMPERATURE CHARACTERISTICS

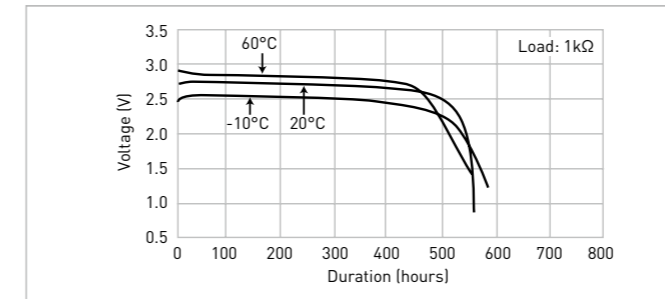

OPERATING VOLTAGE VS. DISCHARGE CURRENT*1

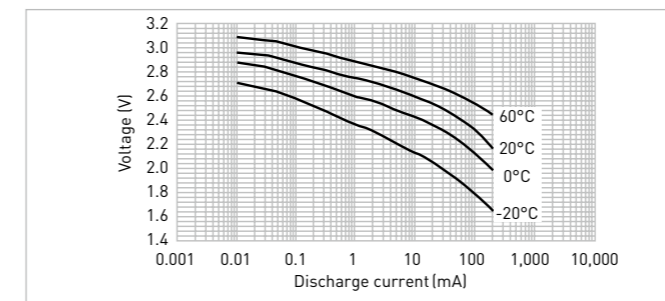

BR-A

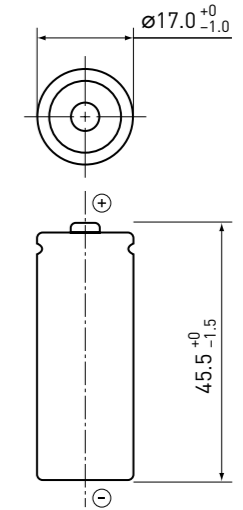

Model number	BR-A
Nominal voltage (V)	3
Nominal capacity (mAh)	1,800
Diameter (mm)	17.0
Total height (mm)	45.5
Discharging temperature range (°C)	-40 to +85
Weight (g)	18.0

DISCHARGE TEMPERATURE CHARACTERISTICS

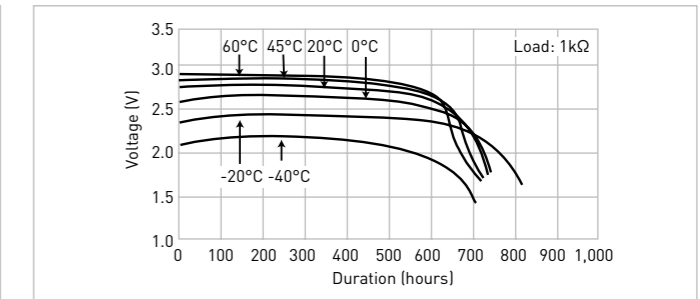

OPERATING VOLTAGE VS. DISCHARGE CURRENT*1

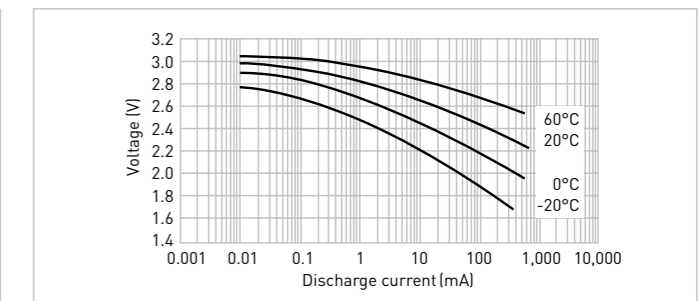

BR-AG

DIMENSIONS (MM)

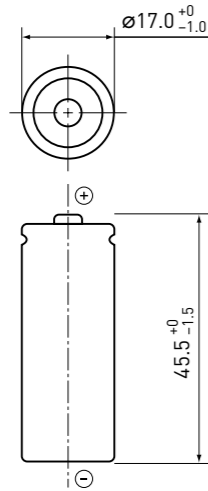

Model number	BR-AG
Nominal voltage (V)	3
Nominal capacity (mAh)	2,200
Diameter (mm)	17.0
Total height (mm)	45.5
Discharging temperature range (°C)	-40 to +85
Weight (g)	18.0

DISCHARGE TEMPERATURE CHARACTERISTICS

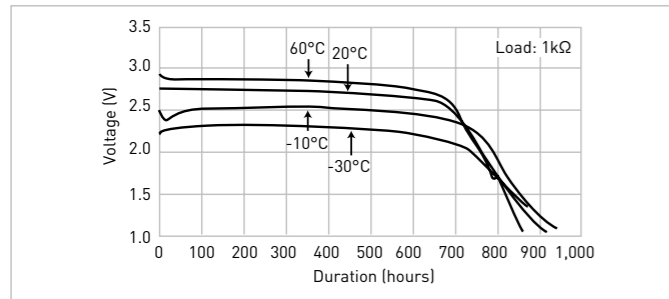

OPERATING VOLTAGE VS. DISCHARGE CURRENT*1

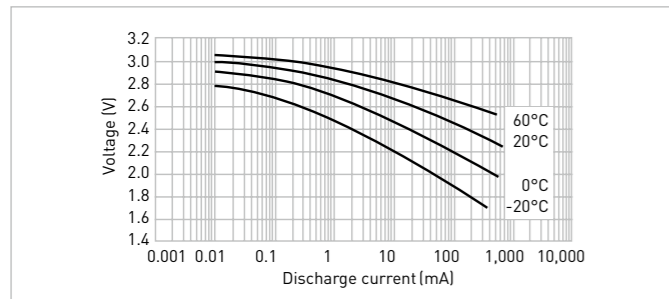

BR-C

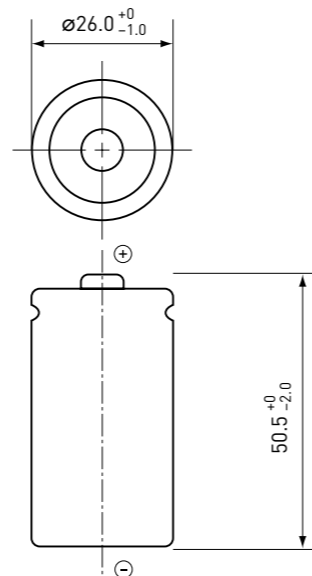

Model number	BR-C
Nominal voltage (V)	3
Nominal capacity (mAh)	5,000
Diameter (mm)	26.0
Total height (mm)	50.5
Discharging temperature range (°C)	-40 to +85
Weight (g)	42.0

DISCHARGE TEMPERATURE CHARACTERISTICS

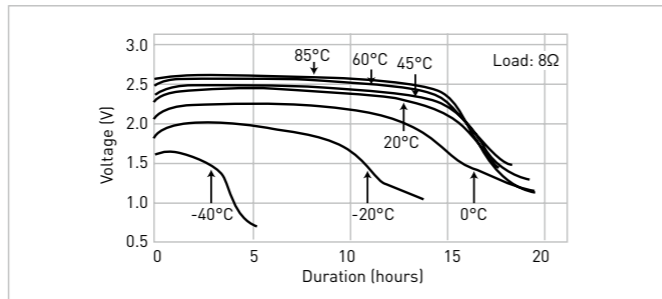

OPERATING VOLTAGE VS. DISCHARGE CURRENT*1

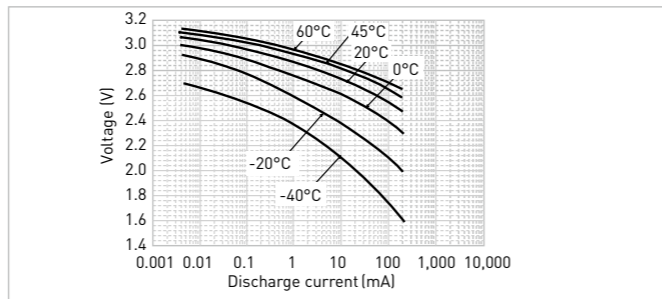

MANGANESE DIOXIDE LITHIUM BATTERIES (CR SERIES FOR CONSUMER) – CYLINDRICAL TYPE LITHIUM BATTERIES

Panasonic Photo-Lithium CR type cylindrical batteries come as either single cells or dual cell packs. All cylindrical type Manganese Dioxide (CR series) Lithium batteries feature a spiral structure. With the enlarged electrode surface areas, they permit a current as high as several amperes to be drawn.

FEATURES

- Operating temperature range: between -40°C ~ +70°C
- Good pulse capability
- Stable voltage level during discharge
- Self discharge rate at 20°C just 1% per year

APPLICATIONS

- Medical equipment
- Door lock systems
- Marine devices
- Cameras
- High energy flashlights
- Sanitary equipment, etc.

Model number	Electrical characteristics at 20°C		Dimensions with tube (mm)		Approx. weight (g)	IEC
	Nominal voltage (V)	Nominal*1 capacity (mAh)	Diameter	Total height		
CR-2*2	3	850	15.6	27.0	11	CR15H270
CR-123A*2	3	1,400	17.0	34.5	17	CR17345
2CR-5*2	6	1,400	34.0 x 17.0	45.0	38	2CR5
CR-P2*2	6	1,400	35.0 x 19.5	36.0	37	CRP2
CR-V3*2	3	3,300	28.4 x 14.4	52.0	39	-

3D ILLUSTRATION*3

- Positive pole
- Vent diaphragm
- Gasket
- Separator
- Anode (Lithium)
- Cathode (Manganese Dioxide)
- Tube
- Insulator
- PTC (Positive Temperature Coefficient Device)
- Collector
- Cell can
- Negative pole



The data in this document are for descriptive purposes only and are not intended to make or imply any guarantee or warranty.

*1 Capacity based on standard drain and cut off voltage down to 2.0V or 4.0V at 20°C.

*2 In case of usage below 20mA discharge please consult Panasonic.

*3 The illustration shows only one example of Lithium battery structure.

CR-2

DIMENSIONS (MM)

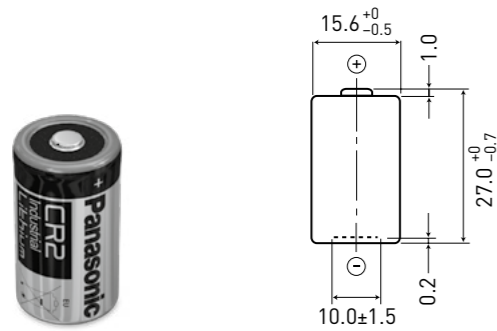

Model number	CR-2
Nominal voltage (V)	3
Nominal capacity (mAh)	850
Diameter (mm)	15.6
Total height (mm)	27.0
Discharging temperature range (°C)	-40 to +70*1
Weight (g)	11.0

DISCHARGE TEMPERATURE CHARACTERISTICS

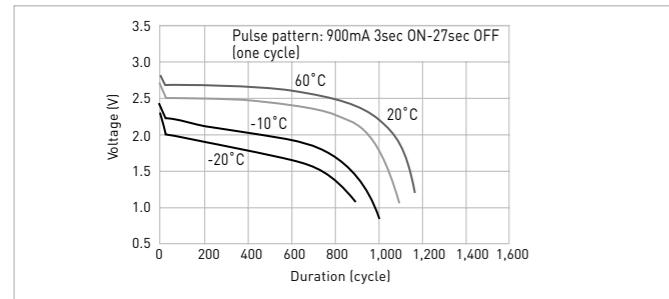

CR-123A

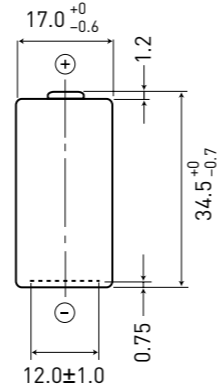

Model number	CR-123A
Nominal voltage (V)	3
Nominal capacity (mAh)	1,400
Diameter (mm)	17.0
Total height (mm)	34.5
Discharging temperature range (°C)	-40 to +70*1
Weight (g)	17.0

DISCHARGE TEMPERATURE CHARACTERISTICS

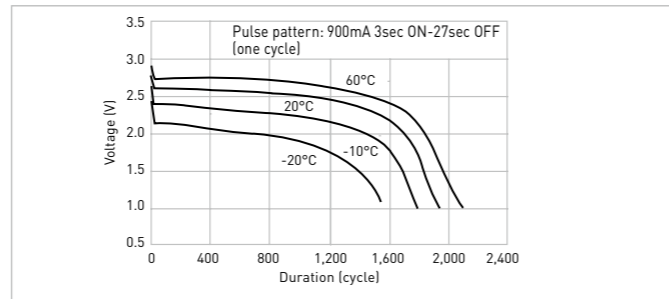

2CR-5

DIMENSIONS (MM)

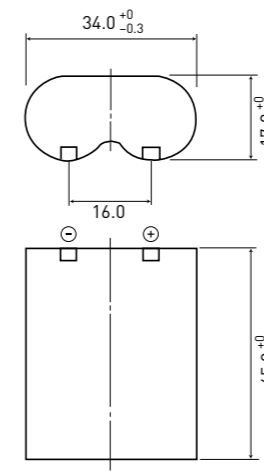

Model number	2CR-5
Nominal voltage (V)	6
Nominal capacity (mAh)	1,400
Diameter (mm)	34.0 x 17.0
Total height (mm)	45.0
Discharging temperature range (°C)	-40 to +70*1
Weight (g)	38.0

DISCHARGE TEMPERATURE CHARACTERISTICS

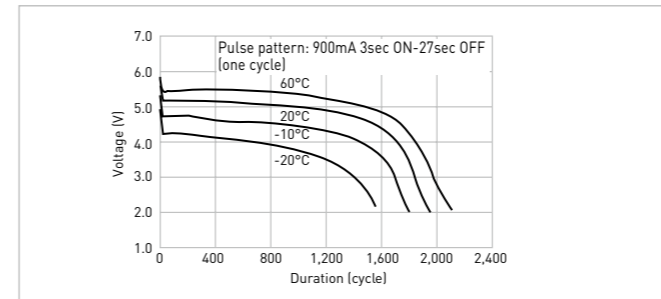

CR-P2

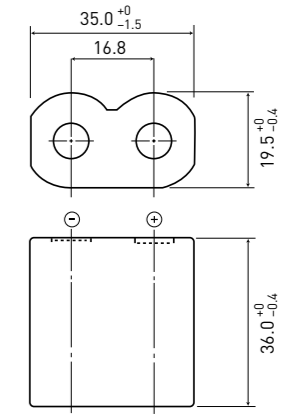

Model number	CR-P2
Nominal voltage (V)	6
Nominal capacity (mAh)	1,400
Diameter (mm)	35.0 x 19.5
Total height (mm)	36.0
Discharging temperature range (°C)	-40 to +70*1
Weight (g)	37.0

DISCHARGE TEMPERATURE CHARACTERISTICS

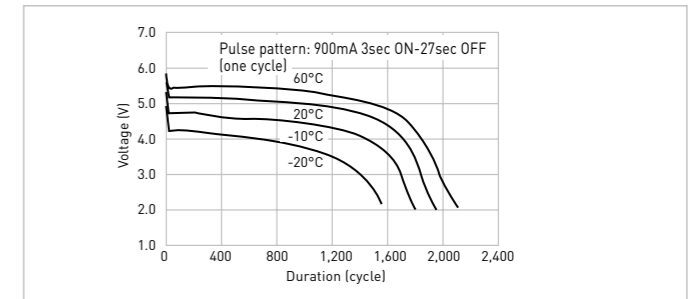

CR-V3

DIMENSIONS (MM)

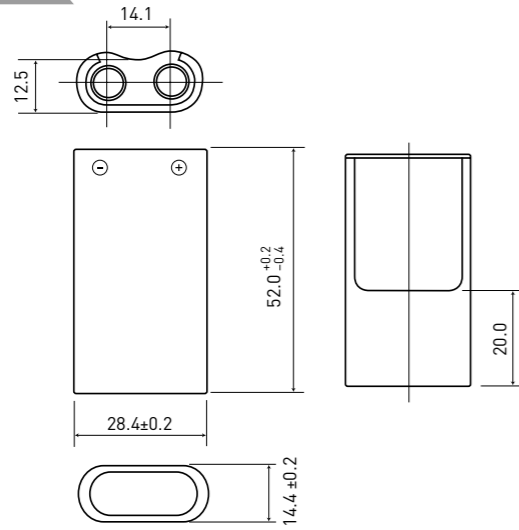

Model number	CR-V3
Nominal voltage (V)	3
Nominal capacity (mAh)	3,300
Diameter (mm)	28.4 x 14.4
Total height (mm)	52.0
Discharging temperature range (°C)	-40 to +70*1
Weight (g)	39.0

DISCHARGE TEMPERATURE CHARACTERISTICS

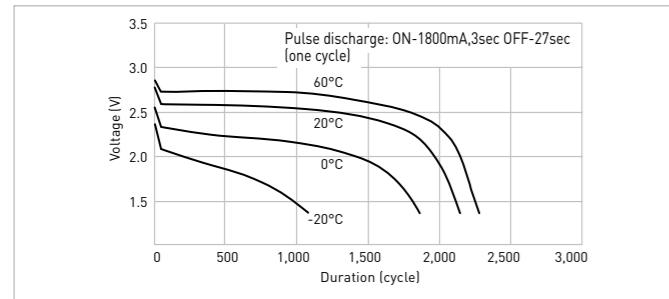

MANGANESE DIOXIDE LITHIUM BATTERIES (CR SERIES FOR PROFESSIONALS) – CYLINDRICAL TYPE LITHIUM BATTERIES

Ideal for industrial equipment, this series offers both excellent high-rate discharge performance and a long service life of up to ten years.

FEATURES

- Stable impedance throughout battery life
- Operating temperature range: between -40°C ~ +70°C
High discharge characteristics
- Long-term reliability
- Self discharge rate at 20°C is just 1% per year

APPLICATIONS

- Medical equipment
- E-Call
- Tracking & RFID
- Smoke detectors
- Alarm systems
- Marine devices, etc.

Model number	Electrical characteristics at 20°C		Dimensions with tube (mm)		Approx. weight (g)	IEC
	Nominal voltage (V)	Nominal*1 capacity (mAh)	Diameter	Total height		
CR-2/3AZ	3	1,600	17	33.5	17	-
CR-AG	3	2,400	17	45.5	24	-

3D ILLUSTRATION*2

- Positive pole
- Vent diaphragm
- Tube
- Anode (Lithium)
- Separator
- Cathode (Manganese Dioxide)
- Insulator
- PTC (Positive Temperature Coefficient Device)
- Collector
- Cell can
- Negative pole



CR-2/3AZ

DIMENSIONS (MM)

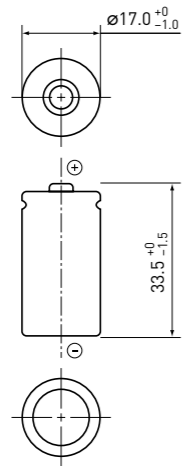

Model number	CR-2/3AZ
Nominal voltage (V)	3
Nominal capacity (mAh)	1,600
Diameter (mm)	17.0
Total height (mm)	33.5
Discharging temperature range (°C)	-40 to +70
Weight (g)	17.0

PULSE DISCHARGE PERFORMANCE

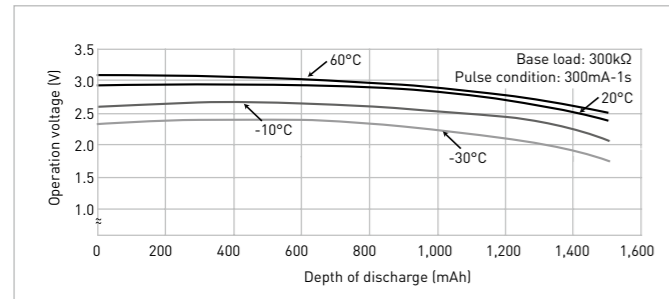

CR-AG

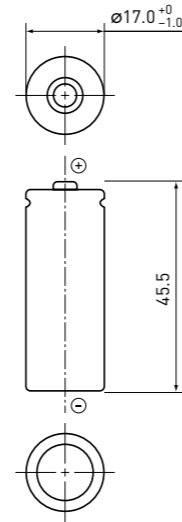

Model number	CR-AG
Nominal voltage (V)	3
Nominal capacity (mAh)	2,400
Diameter (mm)	17.0
Total height (mm)	45.5
Discharging temperature range (°C)	-40 to +70
Weight (g)	24.0

DISCHARGE TEMPERATURE CHARACTERISTICS

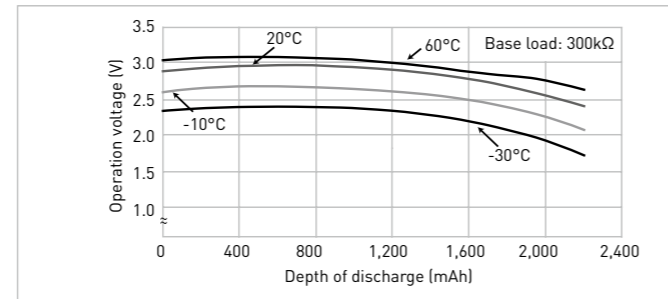

POLY-CARBONMONOFLUORIDE LITHIUM BATTERIES (BR SERIES) – COIN TYPE LITHIUM BATTERIES

Panasonic Lithium BR coin type batteries feature high energy density, and were developed and commercialized using Panasonic's extensive experience in battery technology. They exhibit stable performance under high ambient temperatures.

FEATURES

- ⊕ Self discharge rate at 20°C is just 1.0% per year
- ⊕ Wide operating temperature range: between -30°C ~ +80°C
- ⊕ Superior long-term reliability
- ⊕ Years of experience in production

APPLICATIONS

- ⊕ Tracking & RFID
- ⊕ Memory back-up
- ⊕ Meters, etc.

Model number	Electrical characteristics at 20°C		Dimensions with tube (mm)		Approx. weight (g)	IEC
	Nominal voltage (V)	Nominal*1 capacity (mAh)	Diameter	Total height		
BR-1220	3	35	12.5	2.0	0.7	-
BR-1225	3	48	12.5	2.5	0.8	BR1225
BR-1632	3	120	16.0	3.2	1.5	-
BR-2032	3	200	20.0	3.2	2.5	-
BR-2325	3	165	23.0	2.5	3.0	BR2325
BR-2330	3	255	23.0	3.0	3.2	-
BR-3032	3	500	30.0	3.2	5.5	-

3D ILLUSTRATION*2

- 1 Negative pole
- 2 Anode (Lithium)
- 3 Separator
- 4 Gasket
- 5 Positive pole (cell can)
- 6 Cathode (Poly-Carbonmonofluoride)

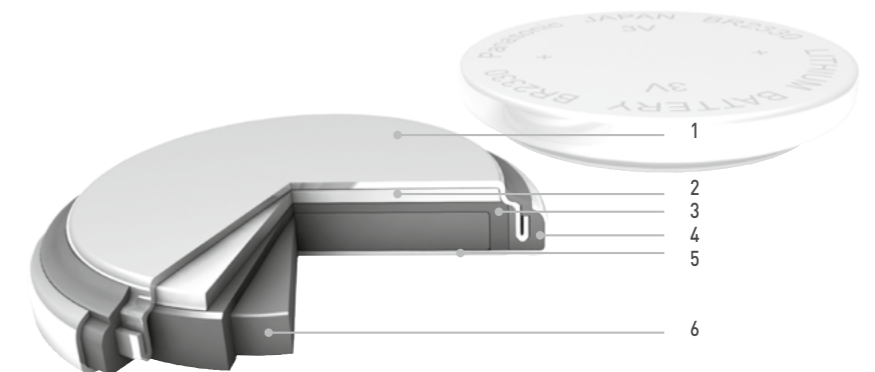

The data in this document are for descriptive purposes only and are not intended to make or imply any guarantee or warranty.

*1 Based on standard drain and cut off voltage down to 2.0V at 20°C.

*2 The illustration shows only one example of Lithium battery structure.

BR-1220

DIMENSIONS (MM)

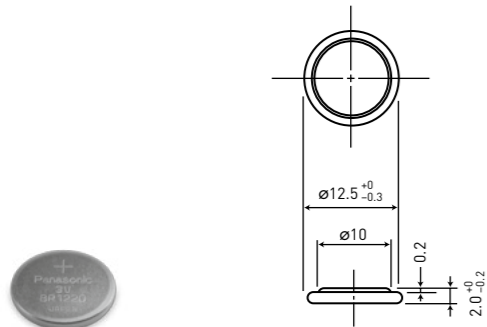

Model number	BR-1220
Nominal voltage (V)	3
Nominal capacity (mAh)	35
Diameter (mm)	12.5
Total height (mm)	2.0
Discharging temperature range (°C)	-30 to +80
Weight (g)	0.7

DISCHARGE TEMPERATURE CHARACTERISTICS

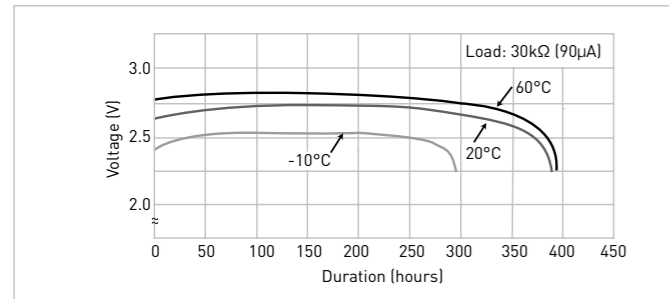

OPERATING VOLTAGE VS. DISCHARGE CURRENT*1

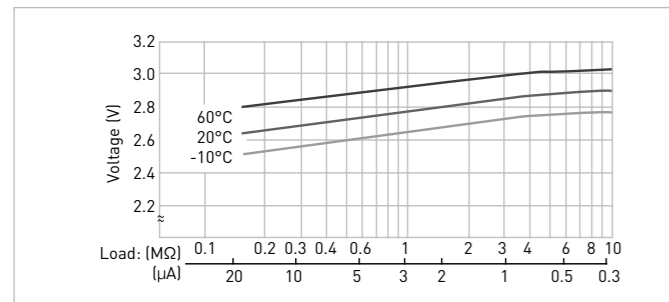

CAPACITY VS. LOAD RESISTANCE

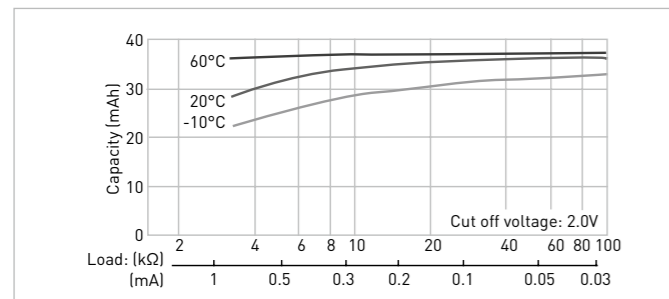

BR-1225

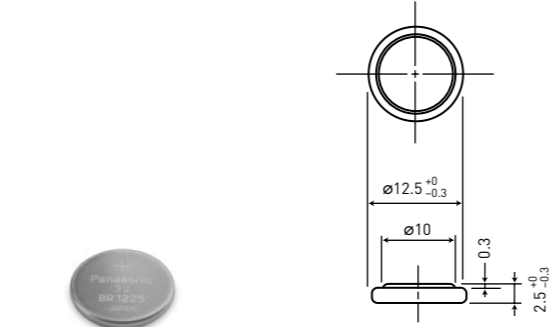

Model number	BR-1225
Nominal voltage (V)	3
Nominal capacity (mAh)	48
Diameter (mm)	12.5
Total height (mm)	2.5
Discharging temperature range (°C)	-30 to +80
Weight (g)	0.8

DISCHARGE TEMPERATURE CHARACTERISTICS

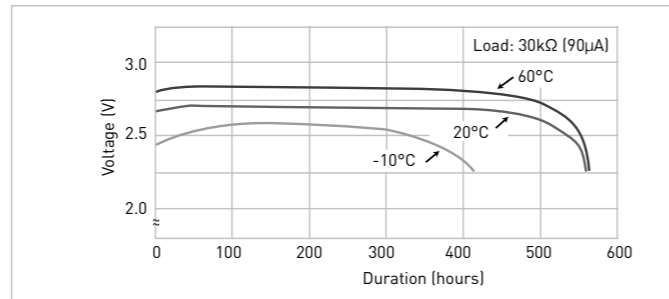

OPERATING VOLTAGE VS. DISCHARGE CURRENT*1

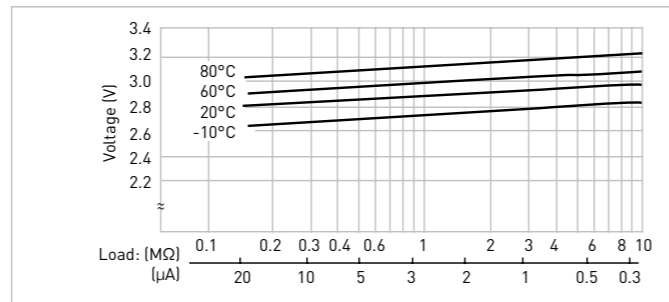

CAPACITY VS. LOAD RESISTANCE

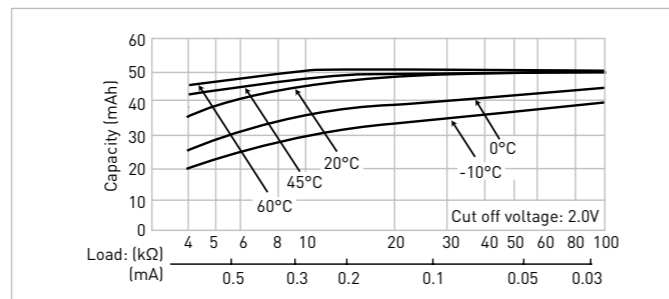

BR-1632

DIMENSIONS (MM)

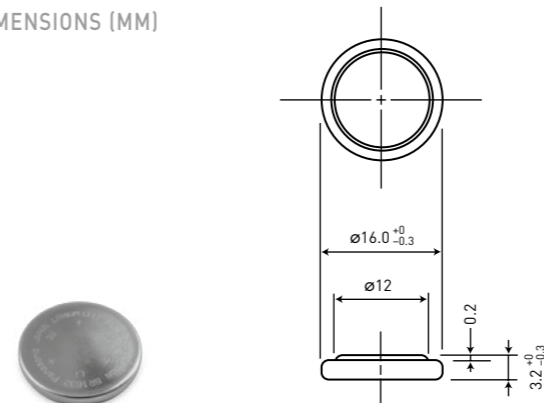

Model number	BR-1632
Nominal voltage (V)	3
Nominal capacity (mAh)	120
Diameter (mm)	16.0
Total height (mm)	3.2
Discharging temperature range (°C)	-30 to +80
Weight (g)	1.5

DISCHARGE TEMPERATURE CHARACTERISTICS

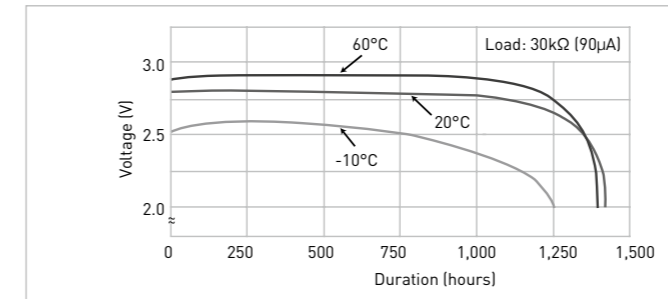

OPERATING VOLTAGE VS. DISCHARGE CURRENT*1

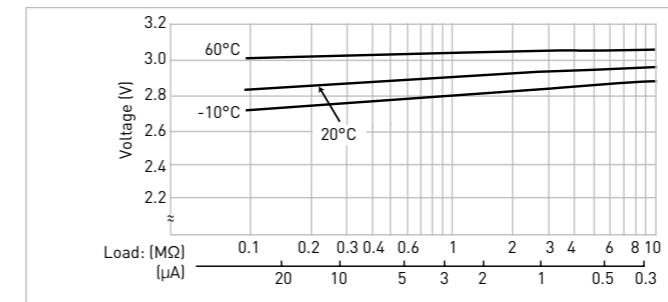

CAPACITY VS. LOAD RESISTANCE

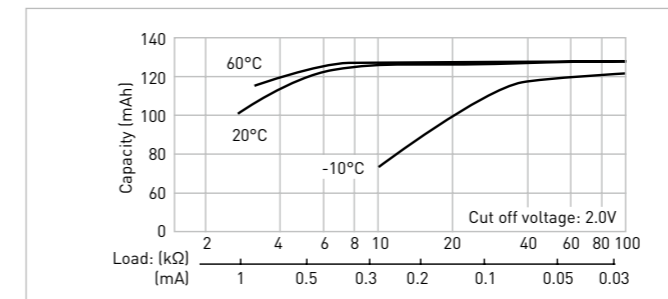

BR-2032

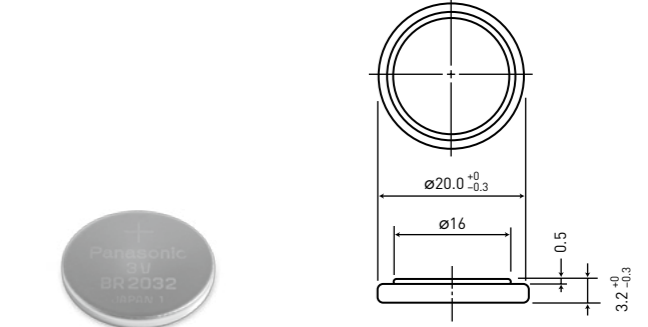

Model number	BR-2032
Nominal voltage (V)	3
Nominal capacity (mAh)	200
Diameter (mm)	20.0
Total height (mm)	3.2
Discharging temperature range (°C)	-30 to +80
Weight (g)	2.5

DISCHARGE TEMPERATURE CHARACTERISTICS

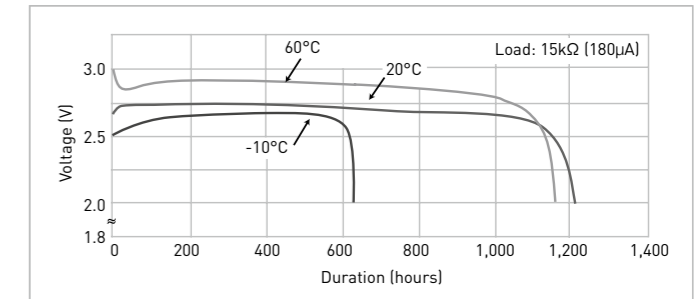

OPERATING VOLTAGE VS. DISCHARGE CURRENT*1

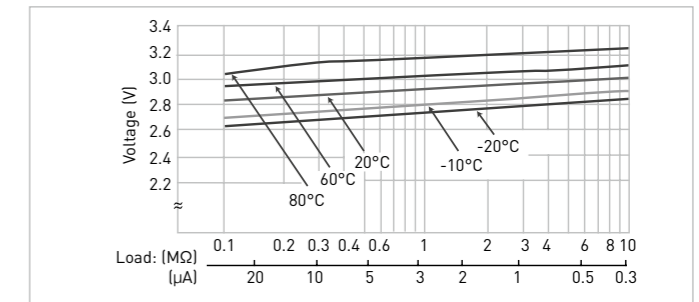

CAPACITY VS. LOAD RESISTANCE

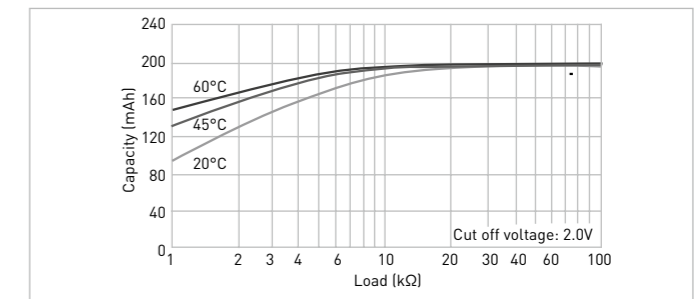

Lithium battery holders for BR-2032

These battery holders are designed for sure and easy loading/removal of Panasonic coin type Lithium batteries in/from equipment enabling the batteries to fully exploit their capabilities as the back-up power supply in C-MOS RAM memory and microcomputer memory. All of the battery holders are designed to prevent inverted insertion of the battery.



BCR20H4 (3 terminals)

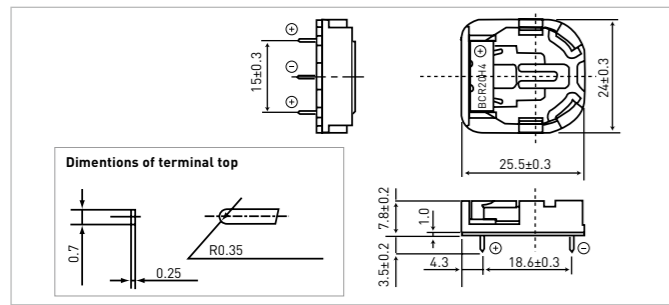

BCR20H5 (2 terminals)

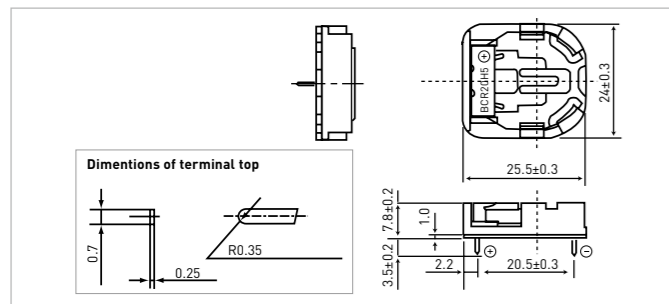

BCR20V4 (3 terminals)

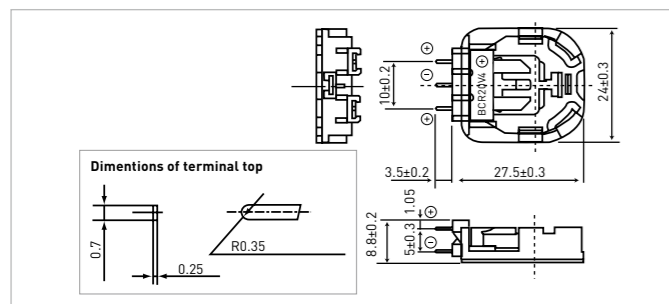

Precaution for washing battery holders

The battery holders can be adversely affected by some detergents use in the circuit board washing process and may result in cracks forming in the holder. Please test the holders in your washing process before use.

BR-2325

DIMENSIONS (MM)

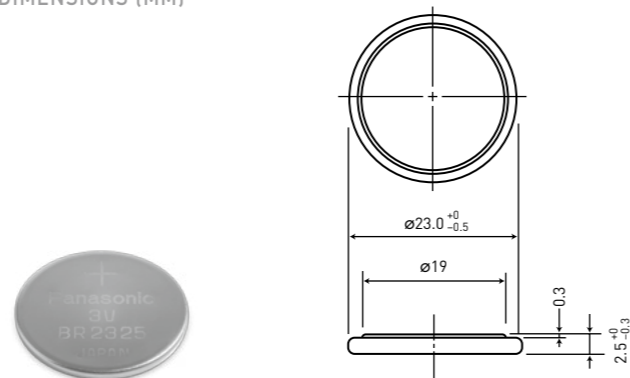

Model number	BR-2325
Nominal voltage (V)	3
Nominal capacity (mAh)	165
Diameter (mm)	23.0
Total height (mm)	2.5
Discharging temperature range (°C)	-30 to +80
Weight (g)	3.0

DISCHARGE TEMPERATURE CHARACTERISTICS

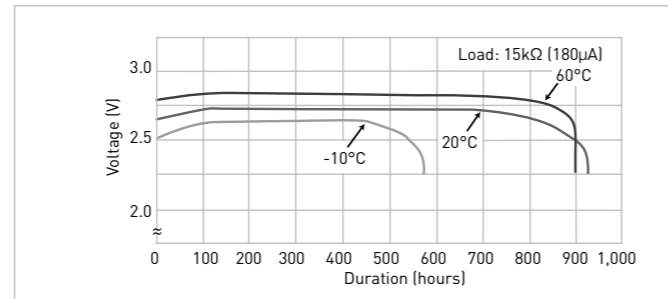

OPERATING VOLTAGE VS. DISCHARGE CURRENT*1

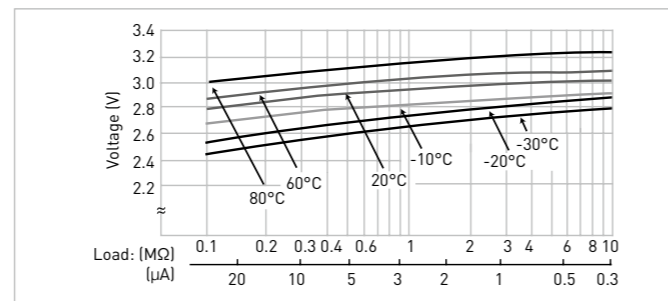

CAPACITY VS. LOAD RESISTANCE

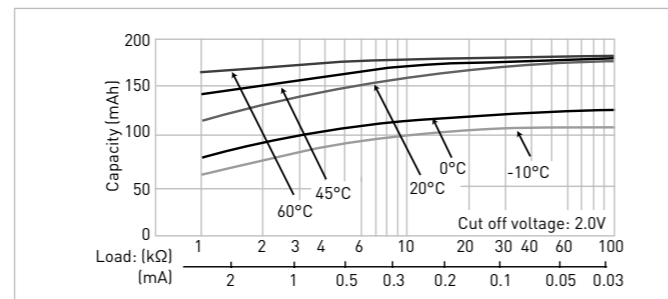

BR-2330

DIMENSIONS (MM)

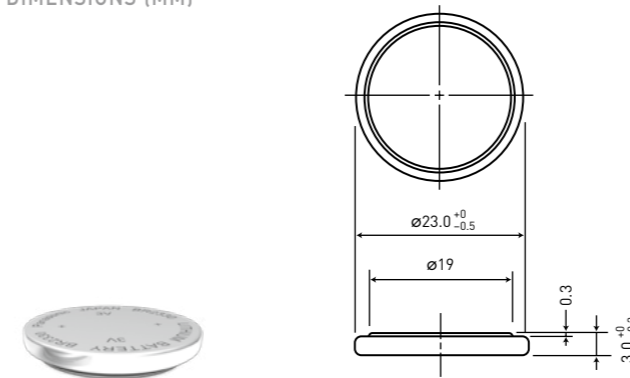

Model number	BR-2330
Nominal voltage (V)	3
Nominal capacity (mAh)	255
Diameter (mm)	23.0
Total height (mm)	3.0
Discharging temperature range (°C)	-30 to +80
Weight (g)	3.2

DISCHARGE TEMPERATURE CHARACTERISTICS

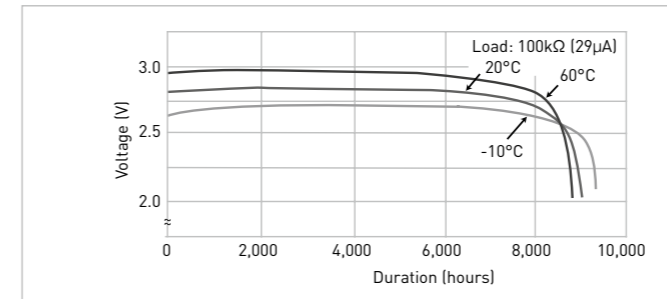

OPERATING VOLTAGE VS. DISCHARGE CURRENT*1

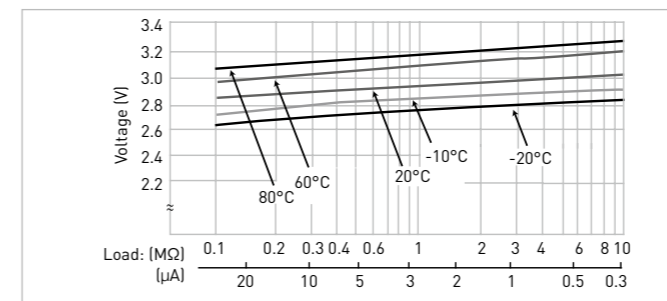

CAPACITY VS. LOAD RESISTANCE

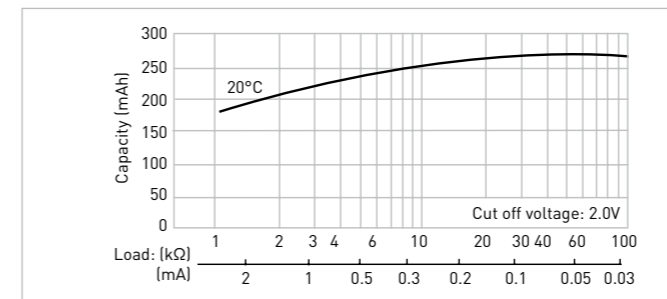

BR-3032

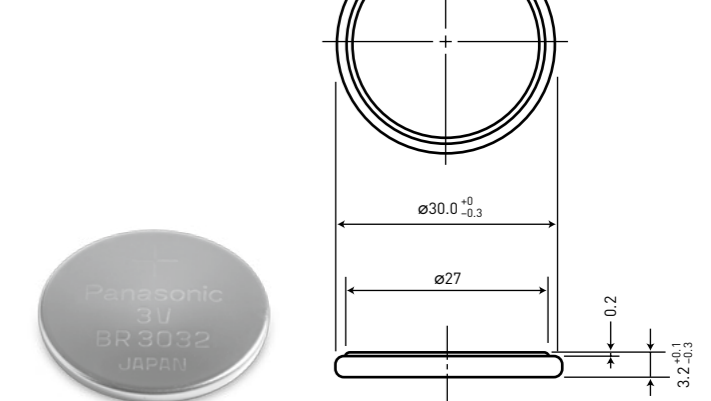

Model number	BR-3032
Nominal voltage (V)	3
Nominal capacity (mAh)	500
Diameter (mm)	30.0
Total height (mm)	3.2
Discharging temperature range (°C)	-30 to +80
Weight (g)	5.5

DISCHARGE TEMPERATURE CHARACTERISTICS

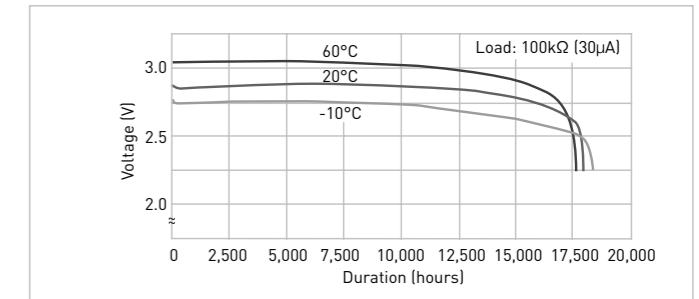

OPERATING VOLTAGE VS. DISCHARGE CURRENT*1

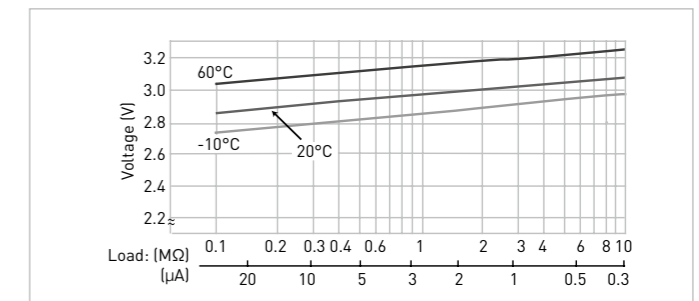

CAPACITY VS. LOAD RESISTANCE

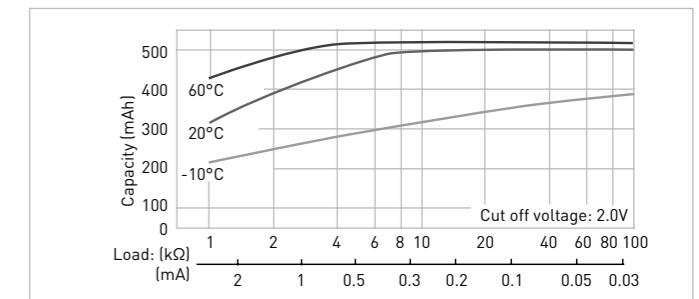



HIGH OPERATING TEMPERATURE POLY-CARBONMONO-FLUORIDE LITHIUM BATTERIES (BR-A SERIES) - COIN TYPE LITHIUM BATTERIES

The high energy density and the special material for gasket and separator make this battery series the ideal power supply in high ambient temperature applications.

FEATURES

- ⊕ Superior design for high temperature applications -40°C ~ +125°C
- ⊕ Outstanding long-term reliability
- ⊕ Years of experience in production
- ⊕ Self discharge rate at 20°C is just 0.5% per year

APPLICATIONS

- ⊕ Tyre Pressure Monitoring Systems (TPMS)
- ⊕ Electronic Toll Collection (ETC)
- ⊕ Heat cost allocators, etc.

Model number	Electrical characteristics at 20°C		Dimensions with tube (mm)		Approx. weight (g)	IEC
	Nominal voltage (V)	Nominal*1 capacity (mAh)	Diameter	Total height		
BR-1225A*2	3	48	12.5	2.5	0.8	-
BR-1632A*2	3	120	16.0	3.2	1.5	-
BR-2330A*2	3	255	23.0	3.0	3.2	-
BR-2450A*2	3	550	24.5	5.0	5.9	-
BR-2477A*2	3	1,000	24.5	7.7	8.0	-

3D ILLUSTRATION*3

- 1 Negative pole
- 2 Anode (Lithium)
- 3 Separator
- 4 Gasket
- 5 Positive pole (cell can)
- 6 Cathode (Poly-Carbonmonofluoride)

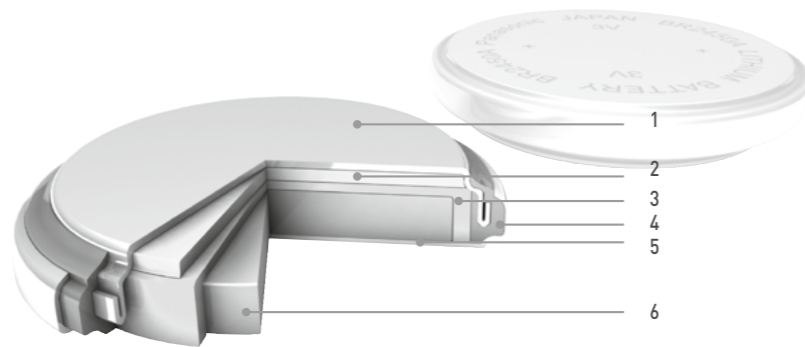

BR-1225A

DIMENSIONS (MM)

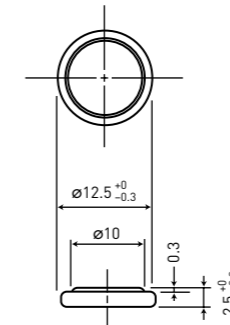

Model number	BR-1225A
Nominal voltage (V)	3
Nominal capacity (mAh)	48
Diameter (mm)	12.5
Total height (mm)	2.5
Discharging temperature range (°C)	-40 to +125
Weight (g)	0.8

DISCHARGE TEMPERATURE CHARACTERISTICS

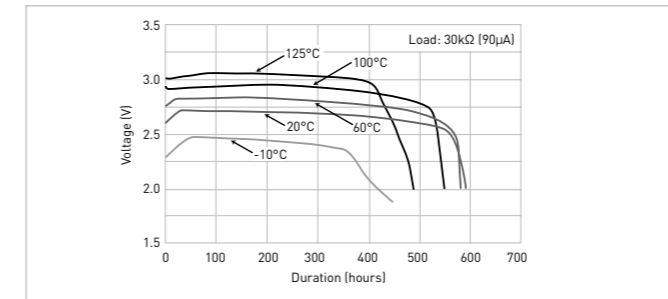

BR-1632A

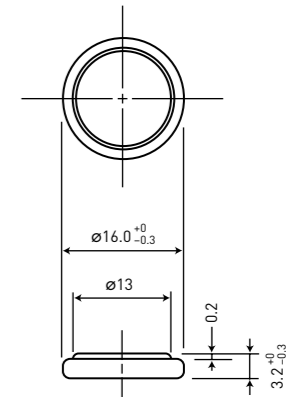

Model number	BR-1632A
Nominal voltage (V)	3
Nominal capacity (mAh)	120
Diameter (mm)	16.0
Total height (mm)	3.2
Discharging temperature range (°C)	-40 to +125
Weight (g)	1.5

DISCHARGE TEMPERATURE CHARACTERISTICS

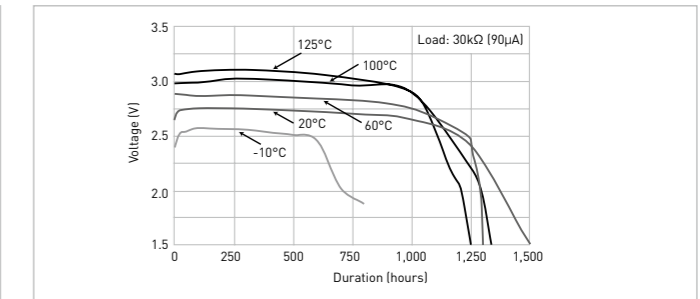

The data in this document are for descriptive purposes only and are not intended to make or imply any guarantee or warranty.

*1 Based on standard drain and cut off voltage down to 2.0V at 20°C.

*2 Only batteries with terminals are available.

*3 The illustration shows only one example of Lithium battery structure.

The data in this document are for descriptive purposes only and are not intended to make or imply any guarantee or warranty.

BR-2330A

DIMENSIONS (MM)

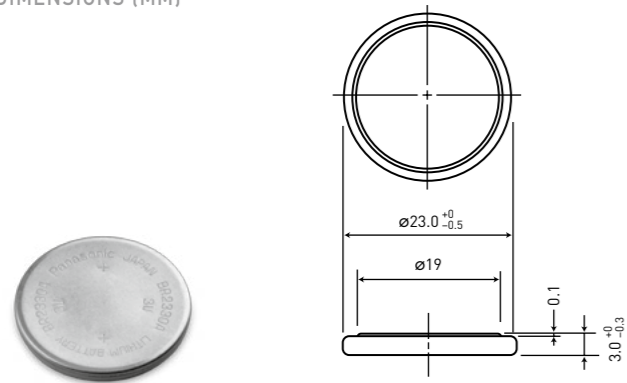

Model number	BR-2330A
Nominal voltage (V)	3
Nominal capacity (mAh)	255
Diameter (mm)	23.0
Total height (mm)	3.0
Discharging temperature range (°C)	-40 to +125
Weight (g)	3.2

DISCHARGE TEMPERATURE CHARACTERISTICS

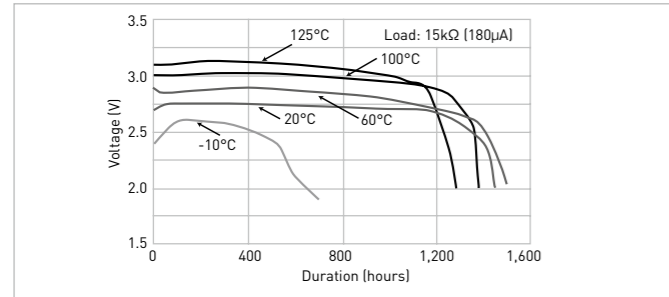

BR-2450A

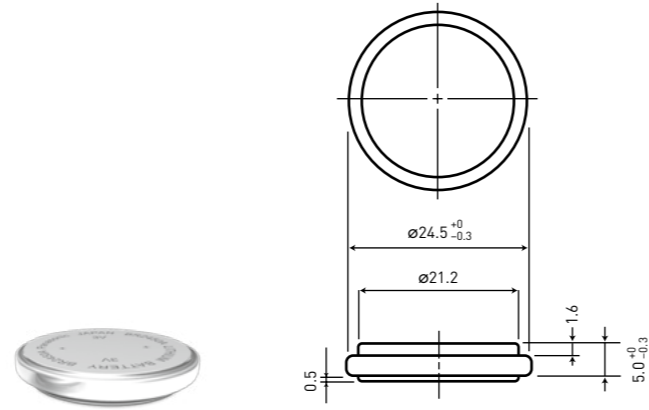

Model number	BR-2450A
Nominal voltage (V)	3
Nominal capacity (mAh)	550
Diameter (mm)	24.5
Total height (mm)	5.0
Discharging temperature range (°C)	-40 to +125
Weight (g)	5.9

DISCHARGE TEMPERATURE CHARACTERISTICS

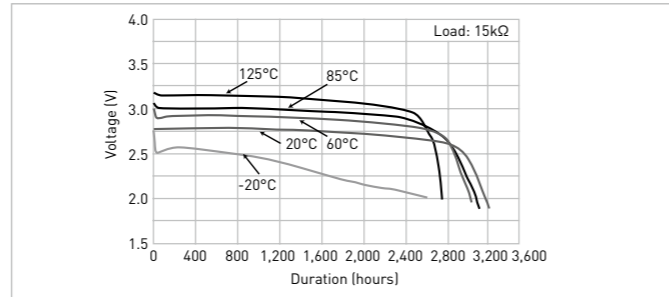

BR-2477A

DIMENSIONS (MM)

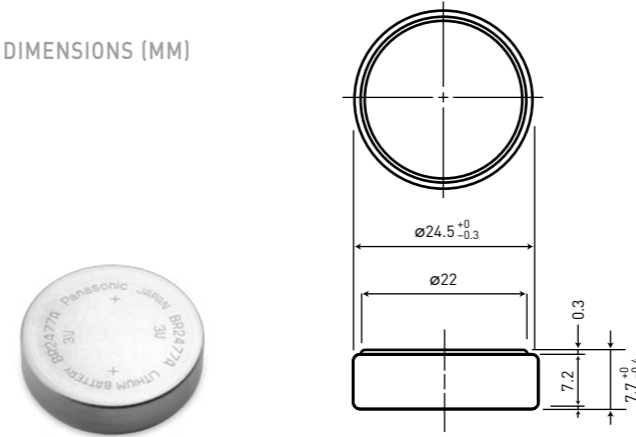

Model number	BR-2477A
Nominal voltage (V)	3
Nominal capacity (mAh)	1,000
Diameter (mm)	24.5
Total height (mm)	7.7
Discharging temperature range (°C)	-40 to +125
Weight (g)	8.0

DISCHARGE TEMPERATURE CHARACTERISTICS

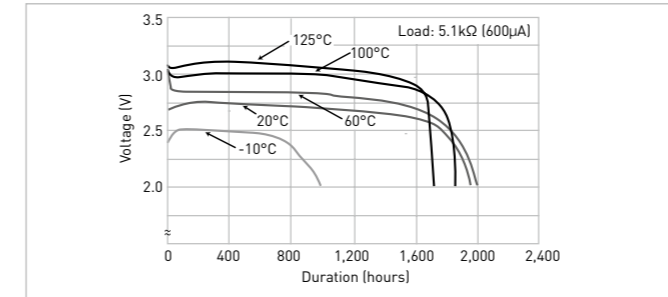



MANGANESE DIOXIDE LITHIUM BATTERIES (CR SERIES) – COIN TYPE LITHIUM BATTERIES

These batteries have a proven track record of excellence in equipment requiring high currents. Additionally Panasonic has many years of manufacturing experience with this battery technology.

FEATURES

- Good pulse capability
- High discharge characteristics
- Stable voltage level during discharge
- Long-term reliability
- Self discharge rate at 20°C is just 1.0% per year
- Temperature range -30°C ~ +60°C

APPLICATIONS

- Remote Keyless Entry (RKE)
- Electricity meters
- Medical equipment
- Tracking & RFID,
- Vending machines,
- Price tags, etc.

Model number	Electrical characteristics at 20°C		Dimensions with tube (mm)		Approx. weight (g)	IEC
	Nominal voltage (V)	Nominal*1 capacity (mAh)	Diameter	Total height		
CR-1025	3	30	10.0	2.5	0.7	CR1025
CR-1216	3	25	12.5	1.6	0.7	CR1216
CR-1220	3	35	12.5	2.0	1.2	CR1220
CR-1612	3	40	16.0	1.2	0.8	-
CR-1616	3	55	16.0	1.6	1.2	CR1616
CR-1620	3	75	16.0	2.0	1.3	CR1620
CR-1632	3	140	16.0	3.2	1.8	-
CR-2012	3	55	20.0	1.2	1.4	CR2012
CR-2016	3	90	20.0	1.6	1.6	CR2016
CR-2025	3	165	20.0	2.5	2.5	CR2025
CR-2032	3	225	20.0	3.2	3.1	CR2032
CR-2330	3	265	23.0	3.0	4.0	CR2330
CR-2354	3	560	23.0	5.4	5.9	CR2354
CR-2412	3	100	24.5	1.2	2.0	-
CR-2450	3	620	24.5	5.0	6.3	CR2450
CR-2477	3	1,000	24.5	7.7	10.5	-
CR-3032	3	500	30.0	3.2	7.1	CR3032

3D ILLUSTRATION*2

- 1 Negative pole
- 2 Anode (Lithium)
- 3 Separator
- 4 Gasket
- 5 Positive pole (cell can)
- 6 Cathode (Manganese Dioxide)

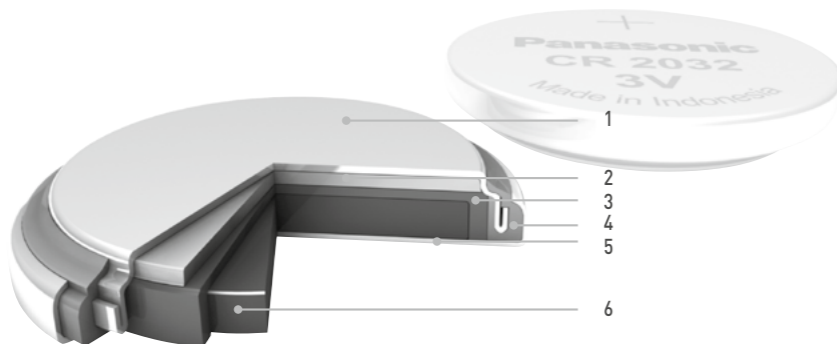

VIDEO



Scan QR code to view 3D animated video.

The data in this document are for descriptive purposes only and are not intended to make or imply any guarantee or warranty.

*1 Based on standard drain and cut off voltage down to 2.0V at 20°C.
*2 The illustration shows only one example of Lithium battery structure.

CR-1025

DIMENSIONS (MM)

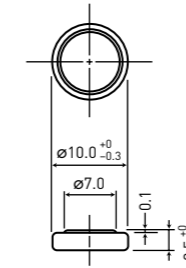

Model number	CR-1025
Nominal voltage (V)	3
Nominal capacity (mAh)	30
Diameter (mm)	10.0
Total height (mm)	2.5
Discharging temperature range (°C)	-30 to +60
Weight (g)	0.7

DISCHARGE TEMPERATURE CHARACTERISTICS

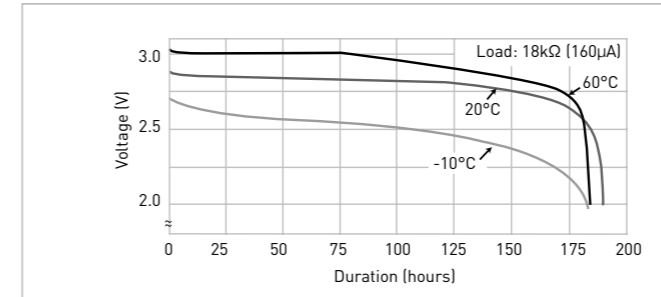

OPERATING VOLTAGE VS. DISCHARGE CURRENT*1

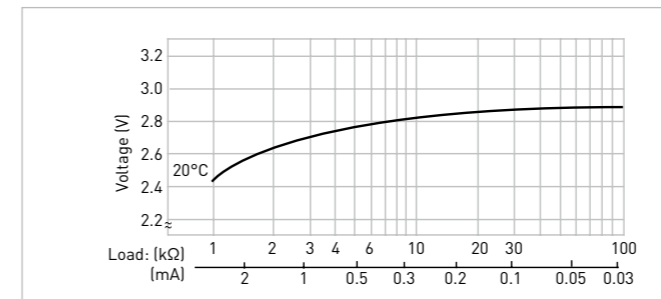

CAPACITY VS. LOAD RESISTANCE

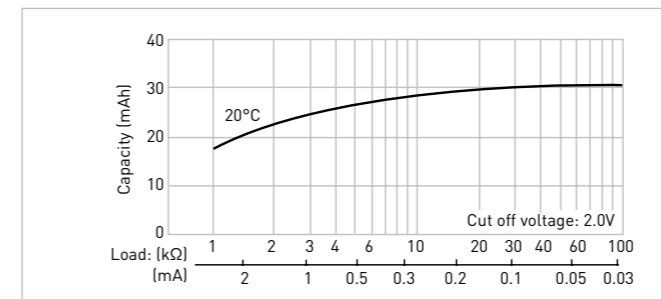

CR-1216

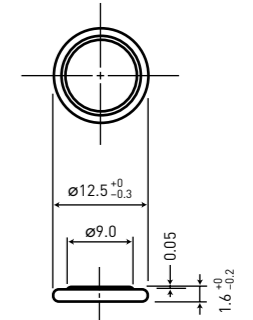

Model number	CR-1216
Nominal voltage (V)	3
Nominal capacity (mAh)	25
Diameter (mm)	12.5
Total height (mm)	1.6
Discharging temperature range (°C)	-30 to +60
Weight (g)	0.7

DISCHARGE TEMPERATURE CHARACTERISTICS

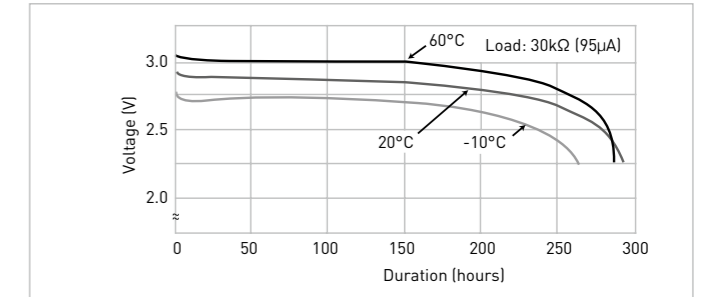

OPERATING VOLTAGE VS. DISCHARGE CURRENT*1

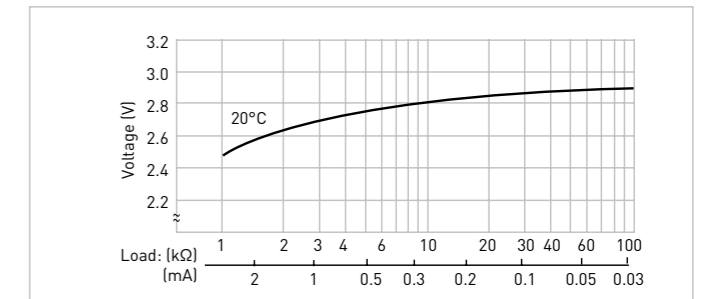

CAPACITY VS. LOAD RESISTANCE

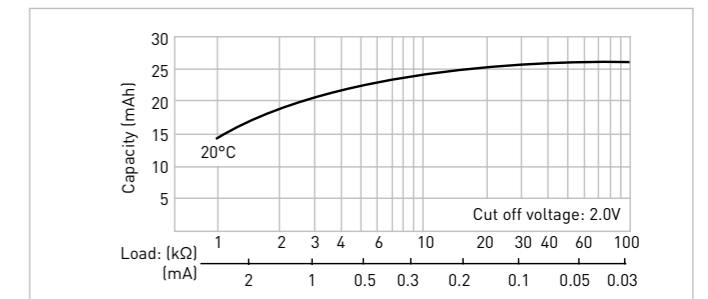

The data in this document are for descriptive purposes only and are not intended to make or imply any guarantee or warranty.

*1 Voltage at 50% discharge depth.

CR-1220

DIMENSIONS (MM)

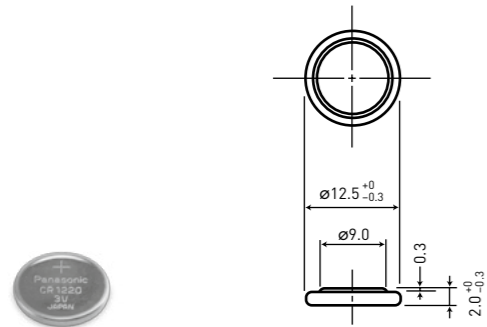

Model number	CR-1220
Nominal voltage (V)	3
Nominal capacity (mAh)	35
Diameter (mm)	12.5
Total height (mm)	2.0
Discharging temperature range (°C)	-30 to +60
Weight (g)	1.2

DISCHARGE TEMPERATURE CHARACTERISTICS

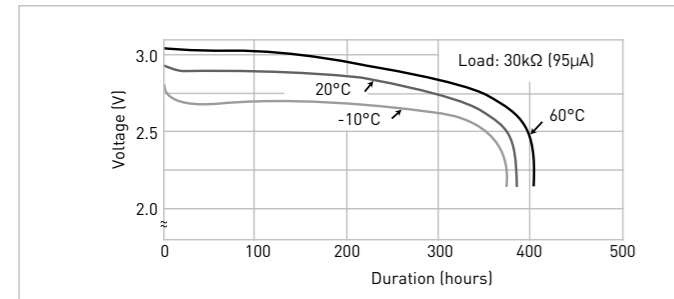

OPERATING VOLTAGE VS. DISCHARGE CURRENT*1

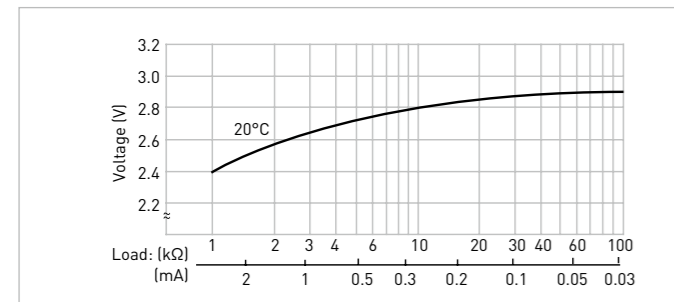

CAPACITY VS. LOAD RESISTANCE

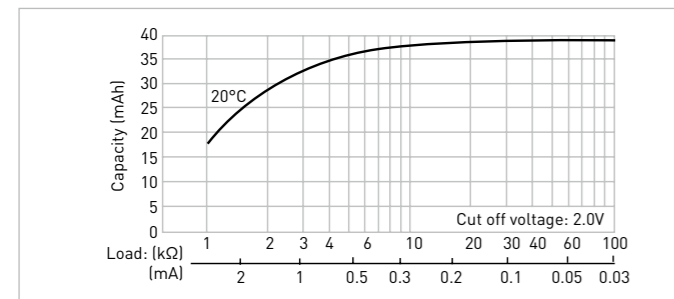

CR-1612

DIMENSIONS (MM)

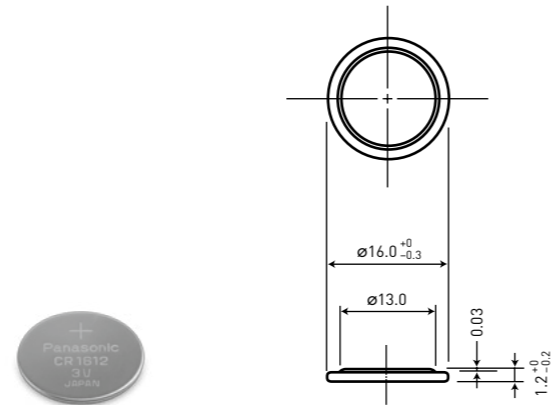

Model number	CR-1612
Nominal voltage (V)	3
Nominal capacity (mAh)	40
Diameter (mm)	16.0
Total height (mm)	1.2
Discharging temperature range (°C)	-30 to +60
Weight (g)	0.8

DISCHARGE TEMPERATURE CHARACTERISTICS

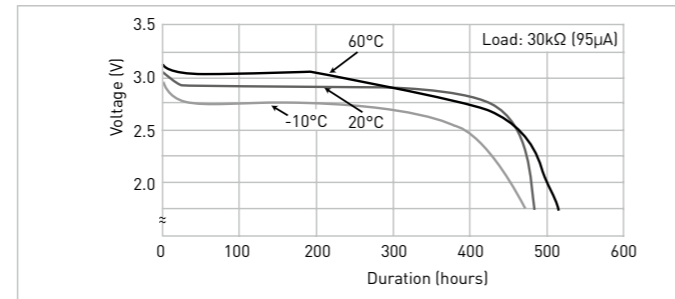

OPERATING VOLTAGE VS. DISCHARGE CURRENT*1

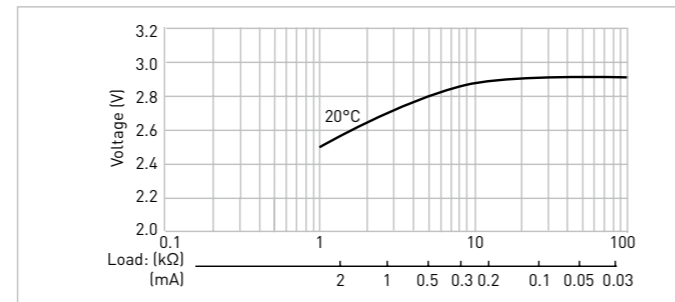

CAPACITY VS. LOAD RESISTANCE

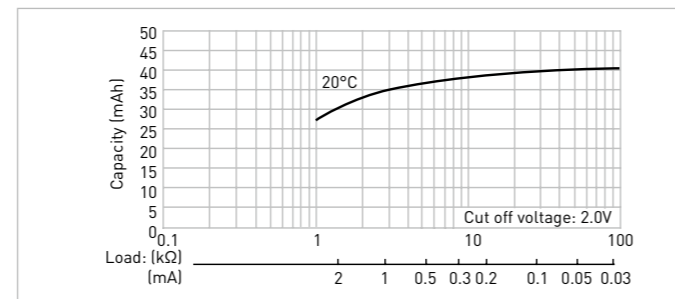

CR-1616

DIMENSIONS (MM)

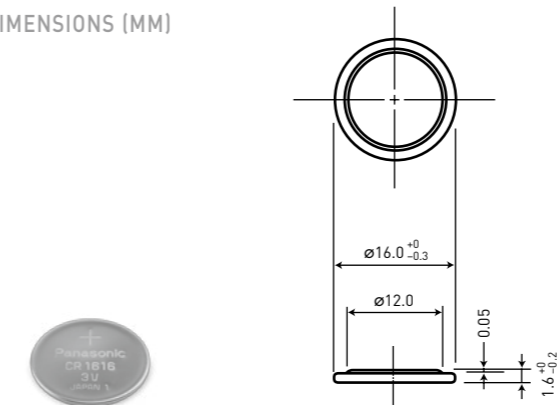

Model number	CR-1616
Nominal voltage (V)	3
Nominal capacity (mAh)	55
Diameter (mm)	16.0
Total height (mm)	1.6
Discharging temperature range (°C)	-30 to +60
Weight (g)	1.2

DISCHARGE TEMPERATURE CHARACTERISTICS

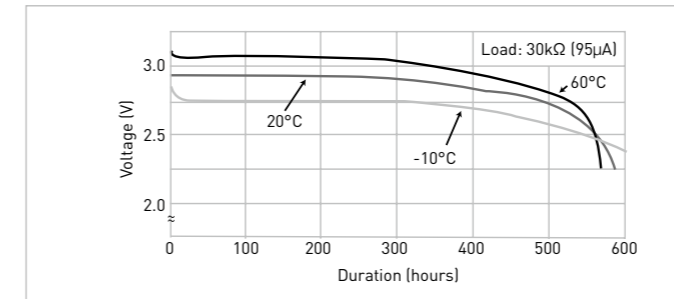

OPERATING VOLTAGE VS. DISCHARGE CURRENT*1

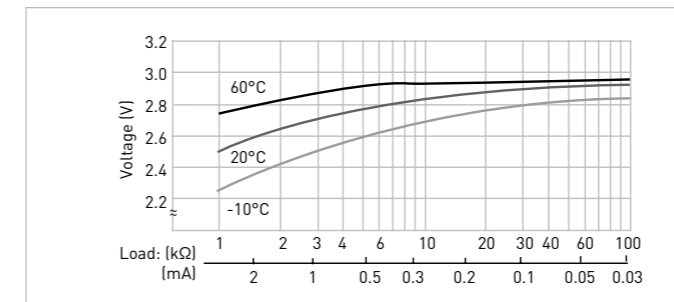

CAPACITY VS. LOAD RESISTANCE

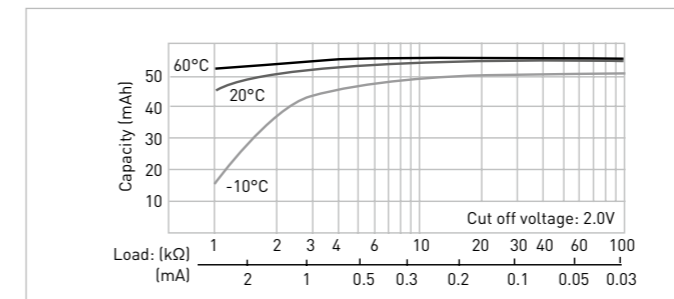

CR-1620

DIMENSIONS (MM)

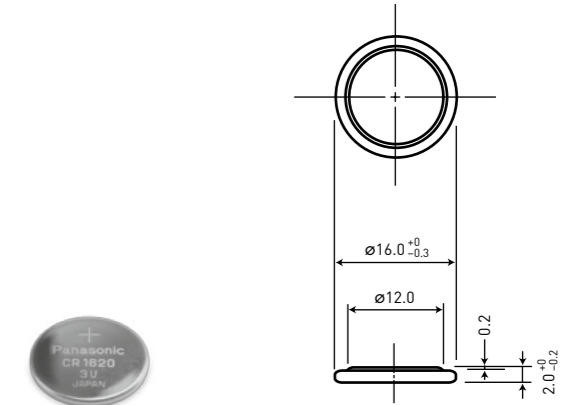

Model number	CR-1620
Nominal voltage (V)	3
Nominal capacity (mAh)	75
Diameter (mm)	16.0
Total height (mm)	2.0
Discharging temperature range (°C)	-30 to +60
Weight (g)	1.3

DISCHARGE TEMPERATURE CHARACTERISTICS

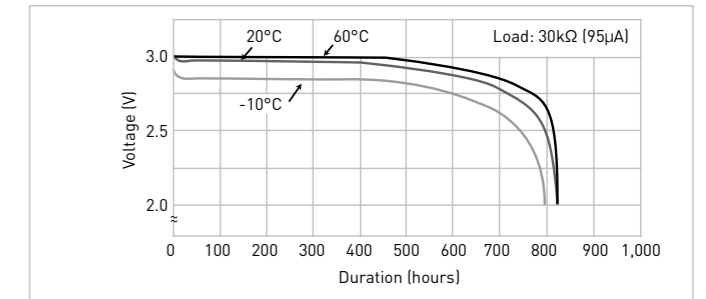

OPERATING VOLTAGE VS. DISCHARGE CURRENT*1

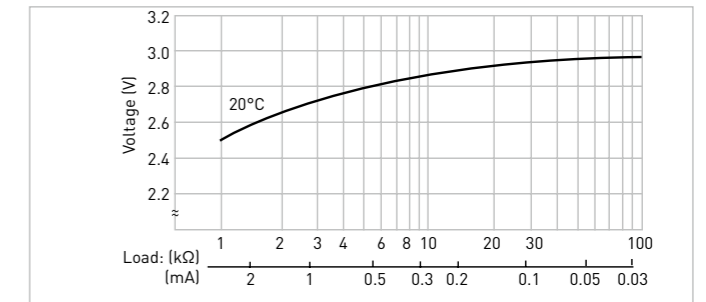

CAPACITY VS. LOAD RESISTANCE

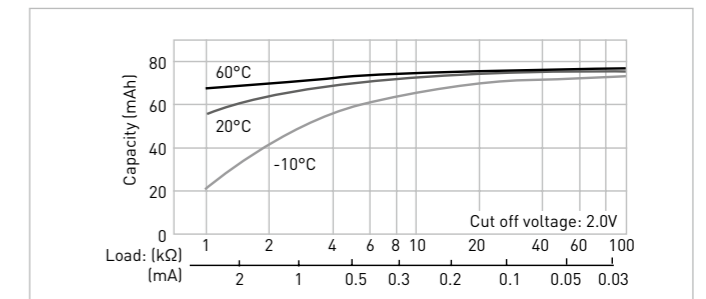

CR-1632

DIMENSIONS (MM)

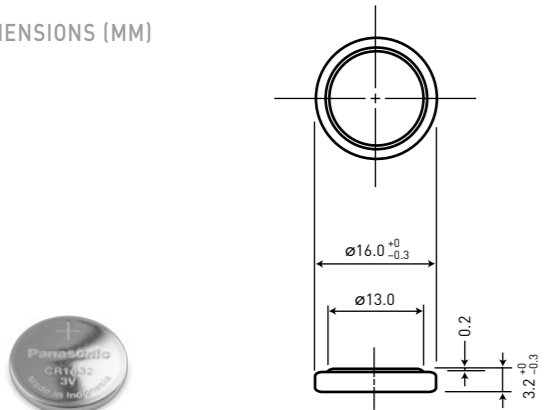

Model number	CR-1632
Nominal voltage (V)	3
Nominal capacity (mAh)	140
Diameter (mm)	16.0
Total height (mm)	3.2
Discharging temperature range (°C)	-30 to +60
Weight (g)	1.8

DISCHARGE TEMPERATURE CHARACTERISTICS

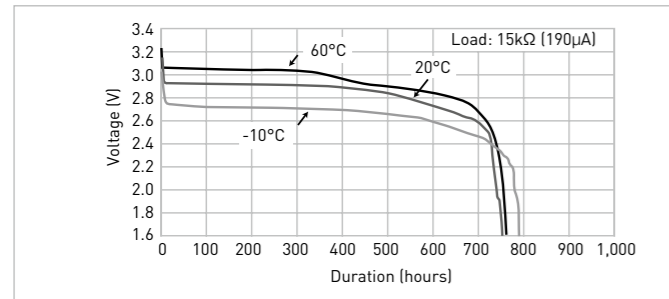

CR-2012



Model number	CR-2012
Nominal voltage (V)	3
Nominal capacity (mAh)	55
Diameter (mm)	20.0
Total height (mm)	1.2
Discharging temperature range (°C)	-30 to +60
Weight (g)	1.4

DISCHARGE TEMPERATURE CHARACTERISTICS

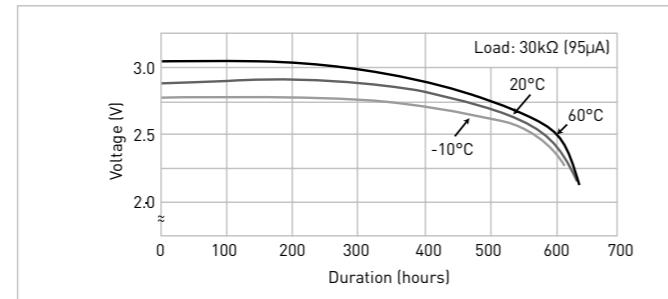

CR-2016

DIMENSIONS (MM)

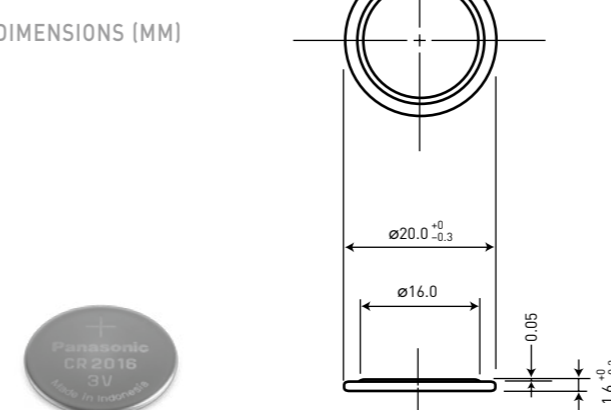

Model number	CR-2016
Nominal voltage (V)	3
Nominal capacity (mAh)	90
Diameter (mm)	20.0
Total height (mm)	1.6
Discharging temperature range (°C)	-30 to +60
Weight (g)	1.6

DISCHARGE TEMPERATURE CHARACTERISTICS

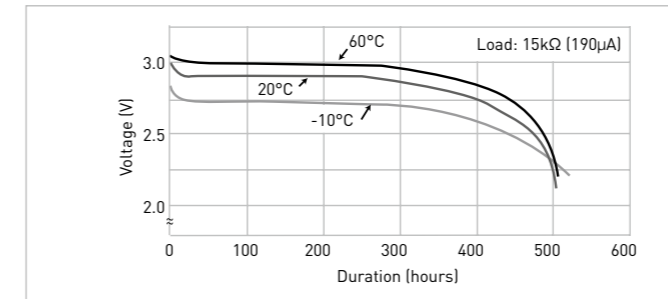

CR-2025

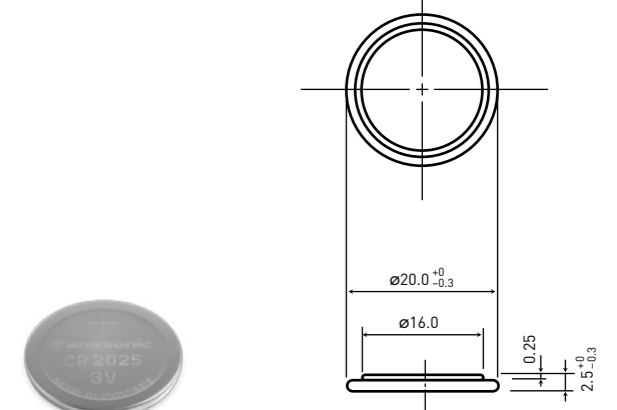

Model number	CR-2025
Nominal voltage (V)	3
Nominal capacity (mAh)	165
Diameter (mm)	20.0
Total height (mm)	2.5
Discharging temperature range (°C)	-30 to +60
Weight (g)	2.5

DISCHARGE TEMPERATURE CHARACTERISTICS

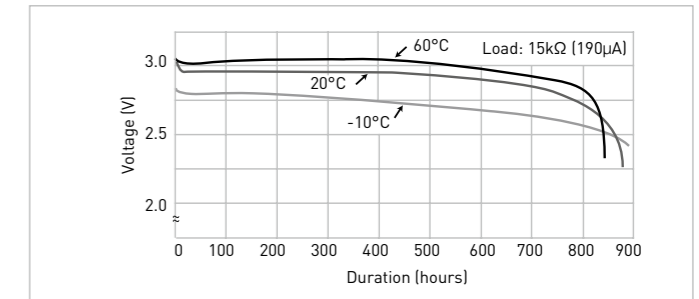

OPERATING VOLTAGE VS. DISCHARGE CURRENT*1

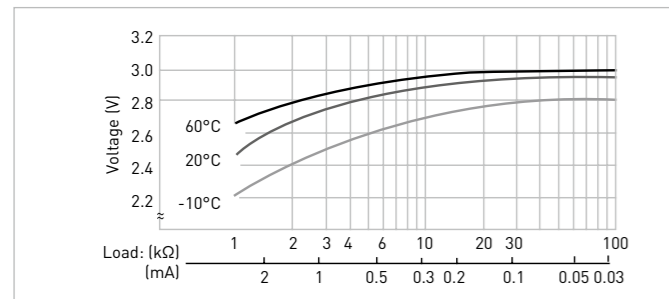

OPERATING VOLTAGE VS. DISCHARGE CURRENT*1

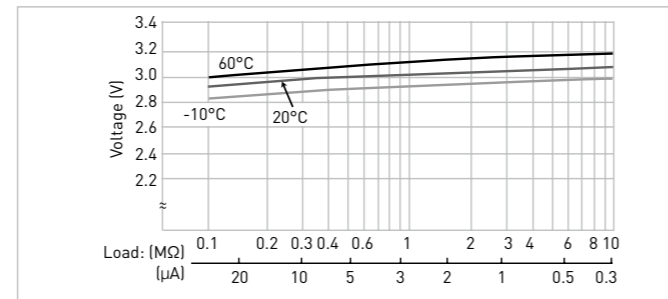

OPERATING VOLTAGE VS. DISCHARGE CURRENT*1

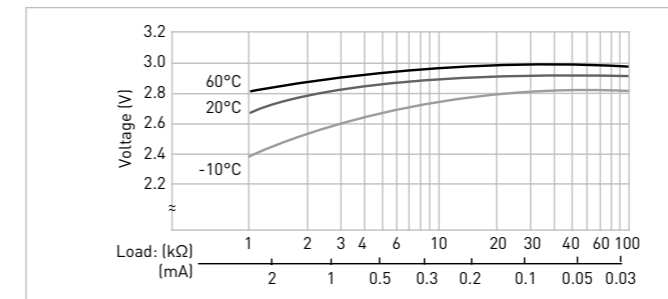

OPERATING VOLTAGE VS. DISCHARGE CURRENT*1

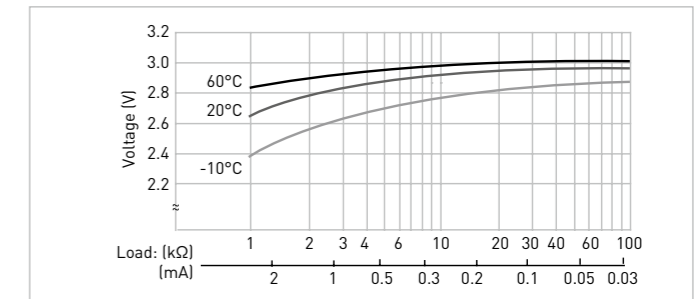

CAPACITY VS. LOAD RESISTANCE

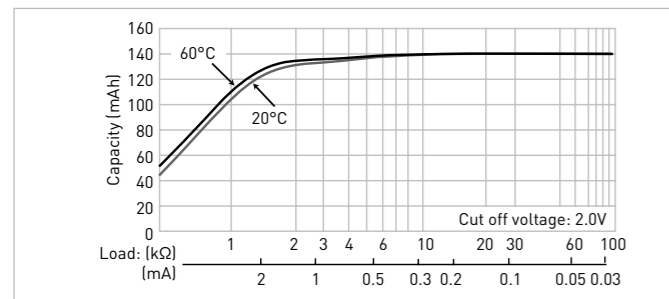

CAPACITY VS. LOAD RESISTANCE

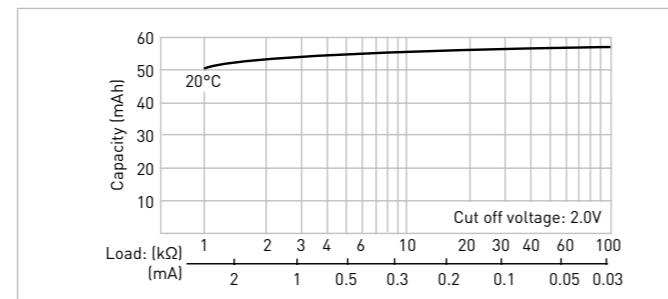

CAPACITY VS. LOAD RESISTANCE

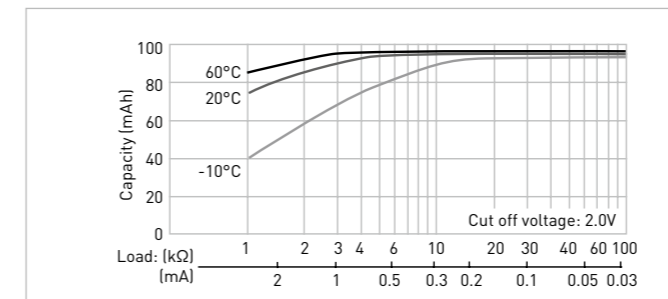

CAPACITY VS. LOAD RESISTANCE

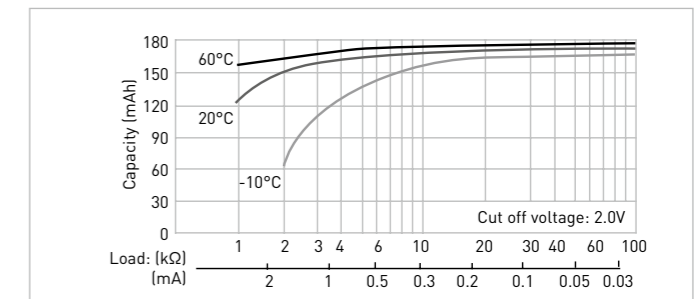

CR-2032

DIMENSIONS (MM)

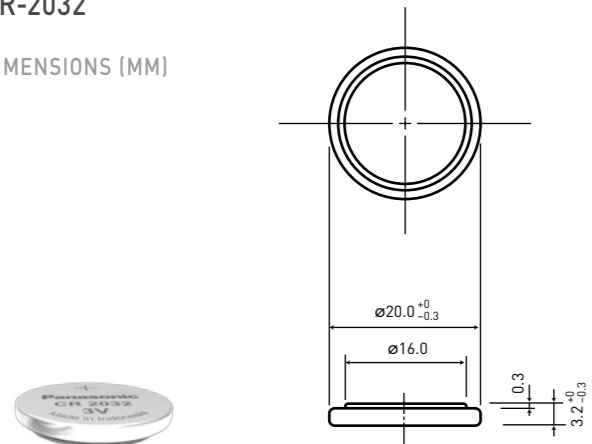

Model number	CR-2032
Nominal voltage (V)	3
Nominal capacity (mAh)	225
Diameter (mm)	20.0
Total height (mm)	3.2
Discharging temperature range (°C)	-30 to +60
Weight (g)	3.1

DISCHARGE TEMPERATURE CHARACTERISTICS

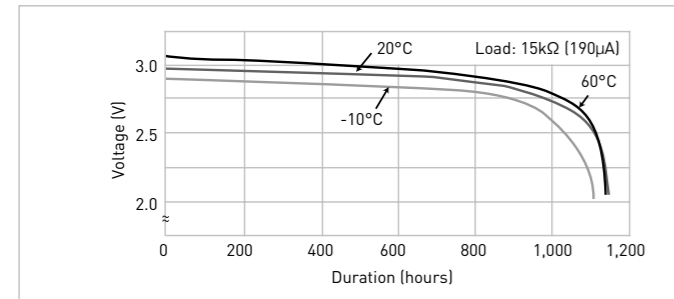

OPERATING VOLTAGE VS. DISCHARGE CURRENT*1

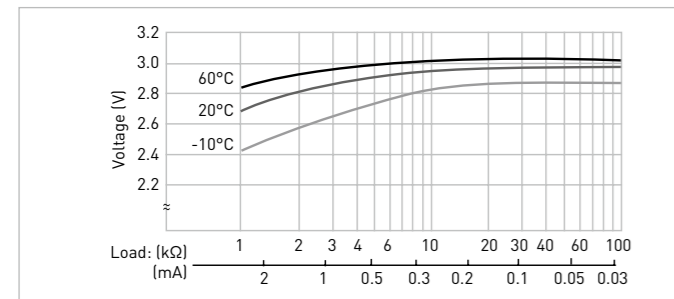

CAPACITY VS. LOAD RESISTANCE

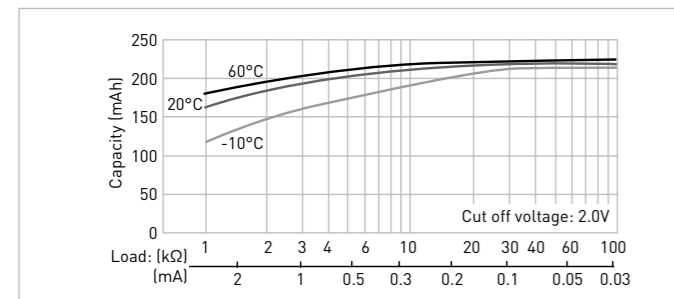

Lithium battery holders for CR-2032

These battery holders are designed for sure and easy loading/removal of Panasonic coin type Lithium batteries in/from equipment enabling the batteries to fully exploit their capabilities as the back-up power supply in C-MOS RAM memory and microcomputer memory. All of the battery holders are designed to prevent inverted insertion of

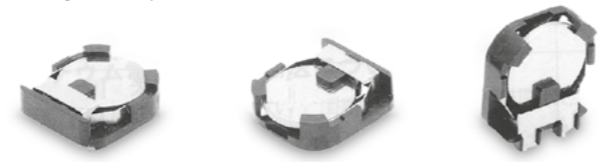

BCR20H4 BCR20H5 BCR20V4

BCR20H4 (3 terminals)

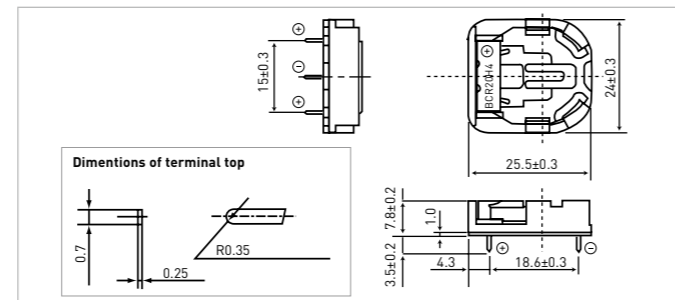

BCR20H5 (2 terminals)

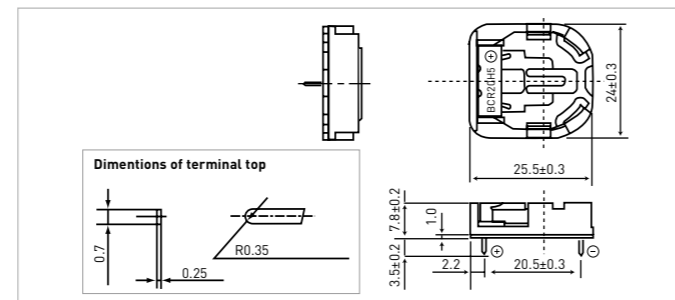

BCR20V4 (3 terminals)

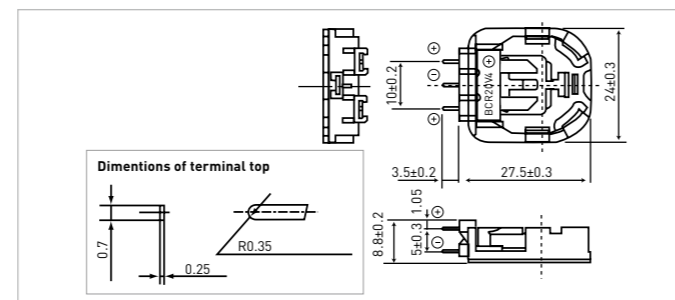

Precaution for washing battery holders

The battery holders can be adversely affected by some detergents use in the circuit board washing process and may result in cracks forming in the holder. Please test the holders in your washing process before use.

CR-2330

DIMENSIONS (MM)

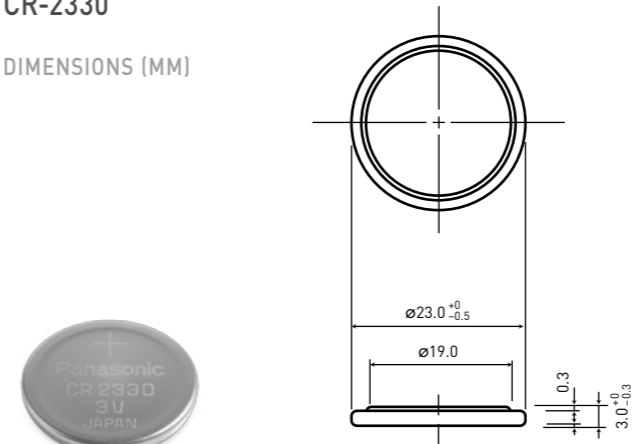

Model number	CR-2330
Nominal voltage (V)	3
Nominal capacity (mAh)	265
Diameter (mm)	23.0
Total height (mm)	3.0
Discharging temperature range (°C)	-30 to +60
Weight (g)	4.0

DISCHARGE TEMPERATURE CHARACTERISTICS

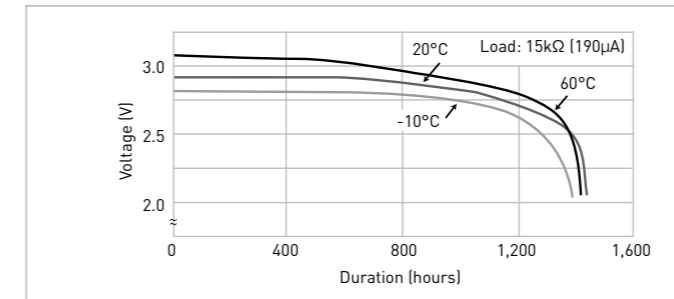

OPERATING VOLTAGE VS. DISCHARGE CURRENT*1

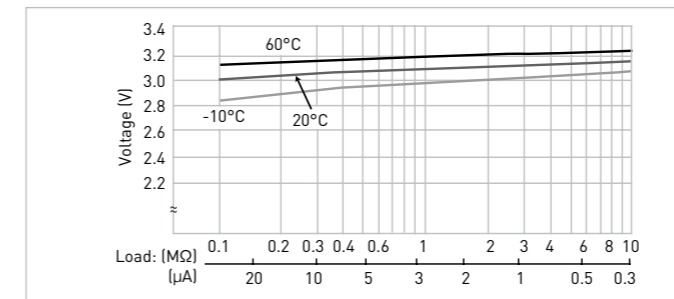

CAPACITY VS. LOAD RESISTANCE

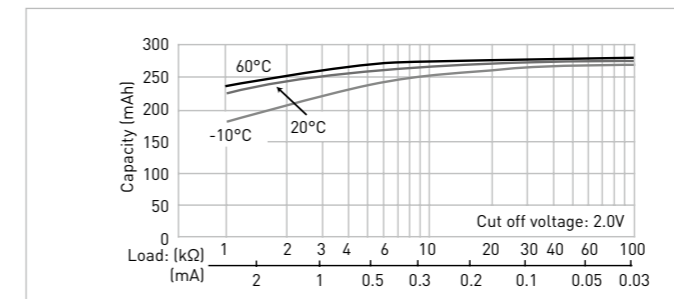

CR-2354

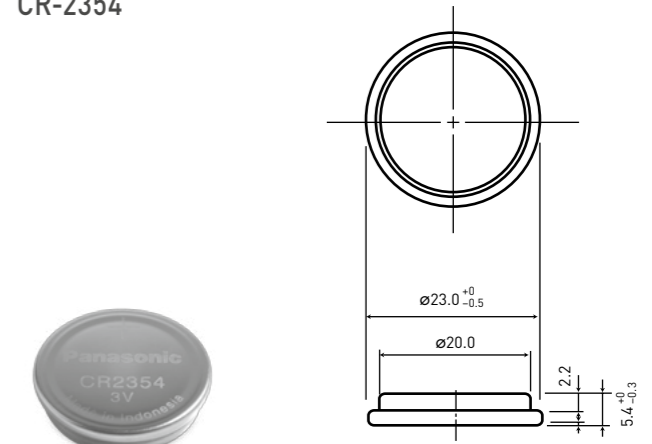

Model number	CR-2354
Nominal voltage (V)	3
Nominal capacity (mAh)	560
Diameter (mm)	23.0
Total height (mm)	5.4
Discharging temperature range (°C)	-30 to +60
Weight (g)	5.9

DISCHARGE TEMPERATURE CHARACTERISTICS

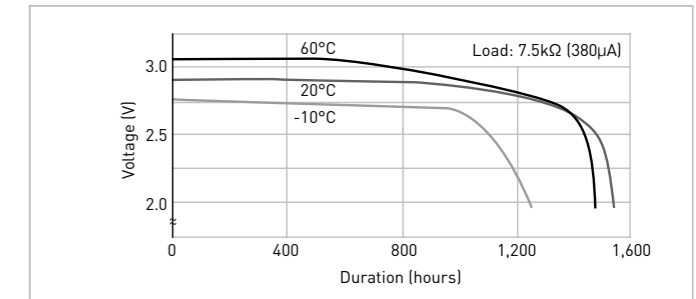

OPERATING VOLTAGE VS. DISCHARGE CURRENT*1

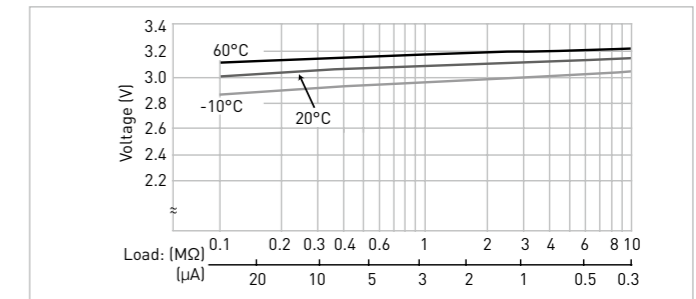

CAPACITY VS. LOAD RESISTANCE

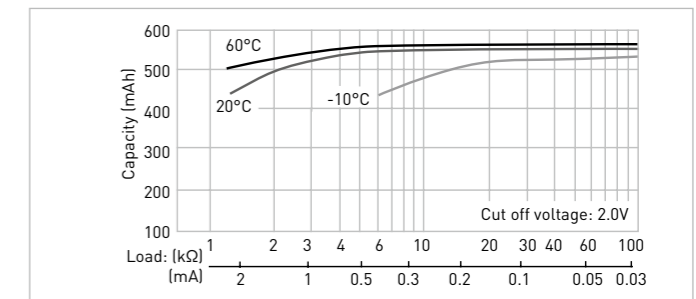

CR-2412

DIMENSIONS (MM)

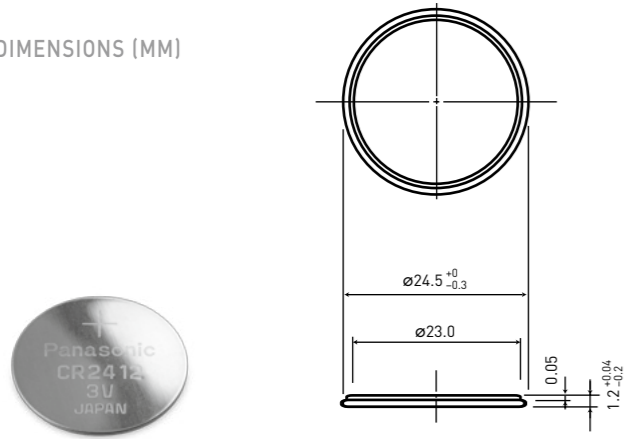

Model number	CR-2412
Nominal voltage (V)	3
Nominal capacity (mAh)	100
Diameter (mm)	24.5
Total height (mm)	1.2
Discharging temperature range (°C)	-30 to +60
Weight (g)	2.0

DISCHARGE TEMPERATURE CHARACTERISTICS

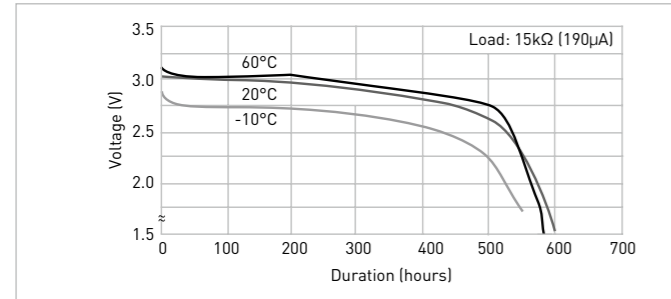

OPERATING VOLTAGE VS. DISCHARGE CURRENT*1

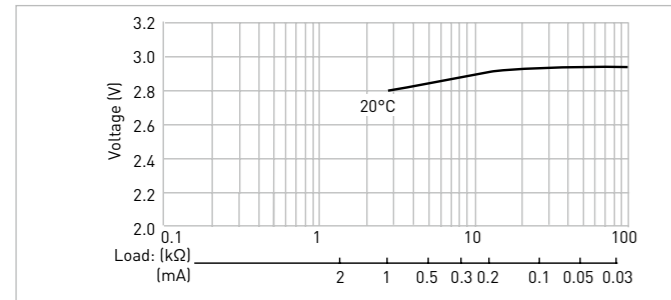

CAPACITY VS. LOAD RESISTANCE

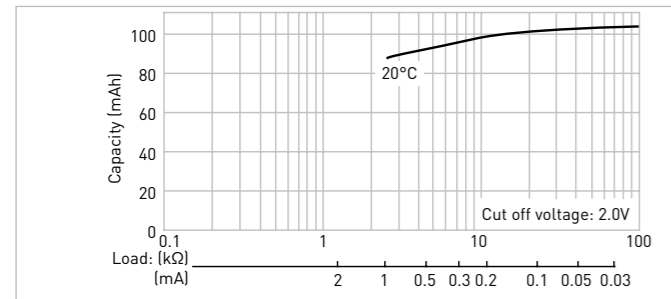

CR-2450

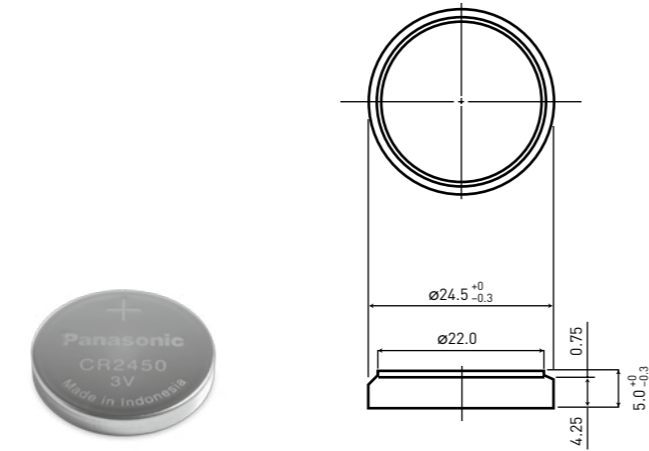

Model number	CR-2450
Nominal voltage (V)	3
Nominal capacity (mAh)	620
Diameter (mm)	24.5
Total height (mm)	5.0
Discharging temperature range (°C)	-30 to +60
Weight (g)	6.3

DISCHARGE TEMPERATURE CHARACTERISTICS

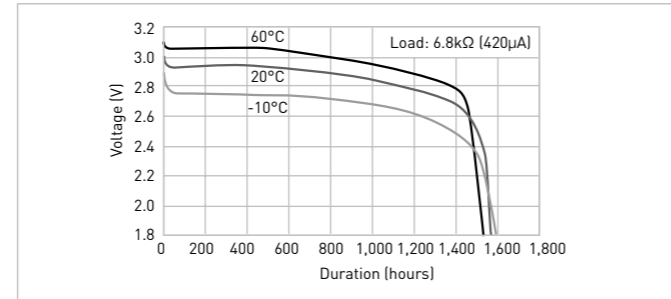

OPERATING VOLTAGE VS. DISCHARGE CURRENT*1

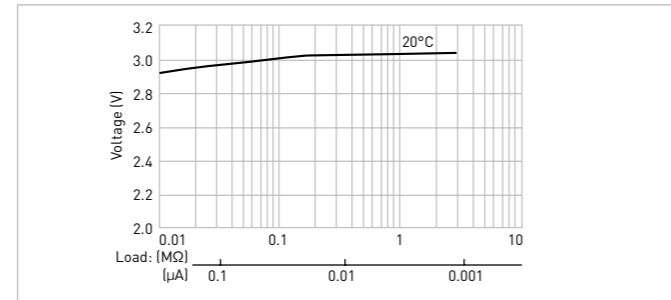

CAPACITY VS. LOAD RESISTANCE

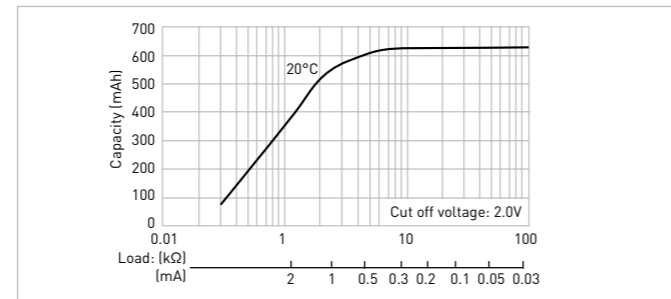

CR-2477

DIMENSIONS (MM)

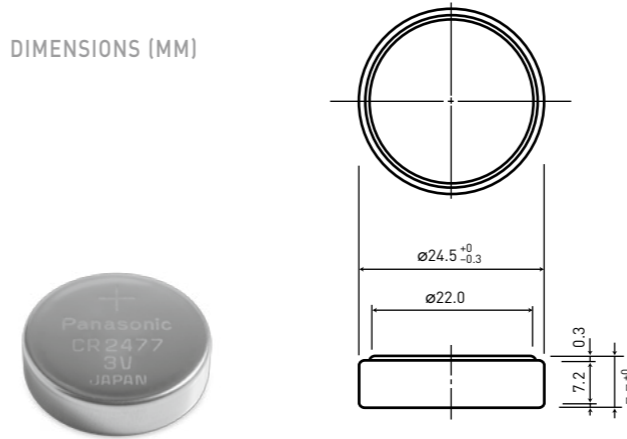

Model number	CR-2477
Nominal voltage (V)	3
Nominal capacity (mAh)	1,000
Diameter (mm)	24.5
Total height (mm)	7.7
Discharging temperature range (°C)	-30 to +60
Weight (g)	10.5

DISCHARGE TEMPERATURE CHARACTERISTICS

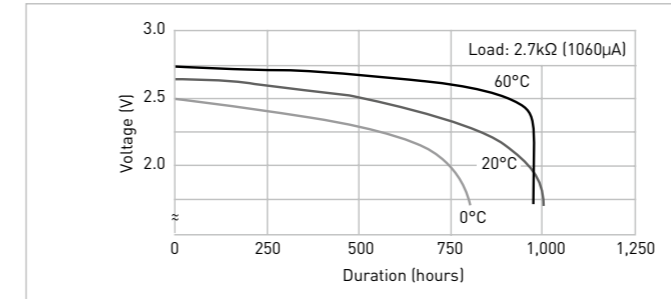

OPERATING VOLTAGE VS. DISCHARGE CURRENT*1

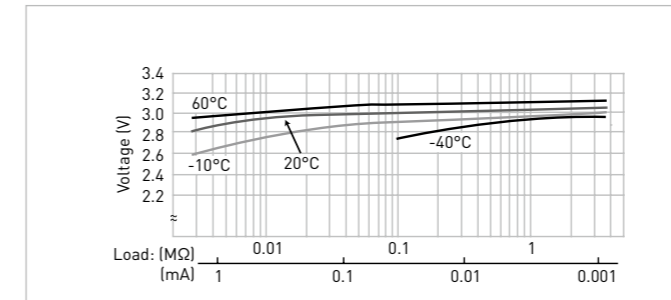

CAPACITY VS. LOAD RESISTANCE

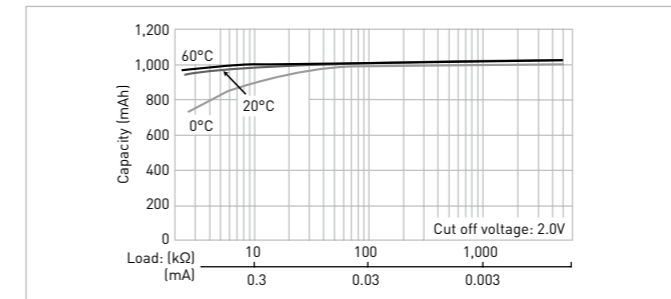

CR-3032

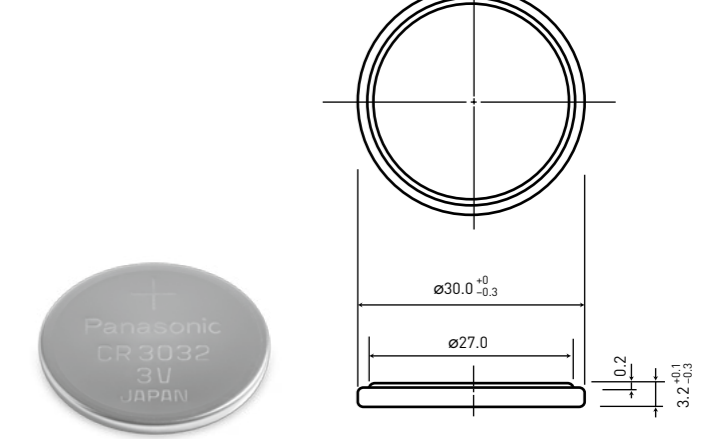

Model number	CR-3032
Nominal voltage (V)	3
Nominal capacity (mAh)	500
Diameter (mm)	30.0
Total height (mm)	3.2
Discharging temperature range (°C)	-30 to +60
Weight (g)	7.1

DISCHARGE TEMPERATURE CHARACTERISTICS

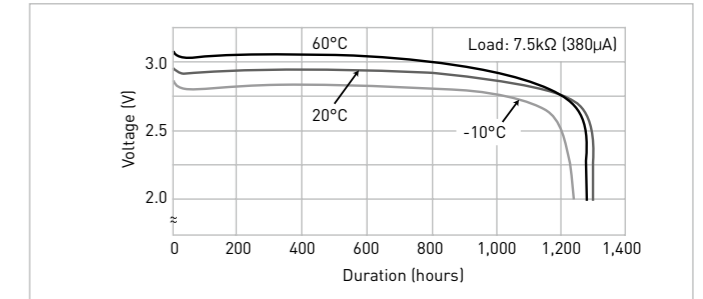

OPERATING VOLTAGE VS. DISCHARGE CURRENT*1

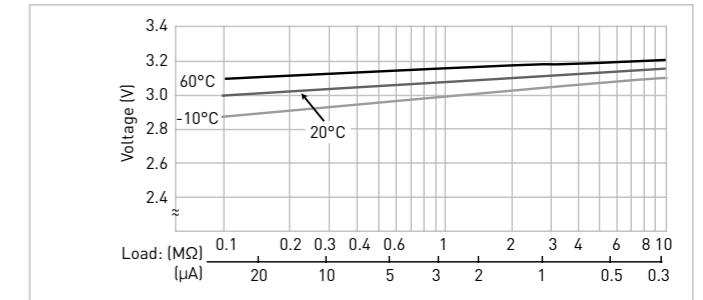

CAPACITY VS. LOAD RESISTANCE

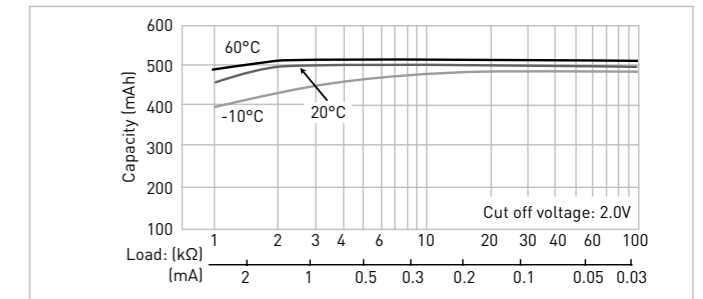



POLY-CARBONMONOFLUORIDE LITHIUM BATTERIES (BR SERIES) – PIN TYPE LITHIUM BATTERIES

Panasonic offers a unique pin shape and space-saving design to meet the requirements of small-scale applications.

FEATURES

- Superior design for high temperature applications -30°C ~ +80°C
- Outstanding long-term reliability
- Years of experience in production
- Self discharge rate at 20°C is just 0.5% per year

APPLICATIONS

- LED-type night fishing floats
- Various illumination products
- Fishing pole tip lights
- Toys, etc.

Model number	Electrical characteristics at 20°C		Dimensions with tube (mm)		Approx. weight (g)	IEC
	Nominal voltage (V)	Nominal*1 capacity (mAh)	Diameter	Total height		
BR-425	3	25.0	4.2	25.9	0.6	-
BR-435	3	50.0	4.2	35.9	0.9	-

3D ILLUSTRATION*2

- Anode cap
- Gasket
- Collector
- Cathode (Poly-Carbonmonofluoride)
- Separator
- Anode (Lithium)

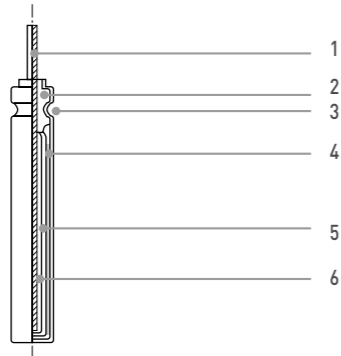

BR-425

DIMENSIONS (MM)

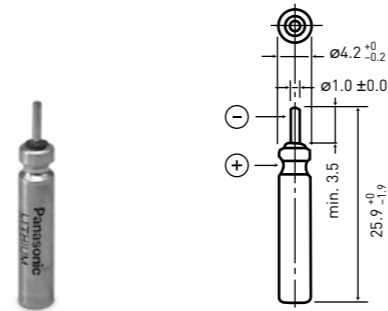

Model number	BR-425
Nominal voltage (V)	3
Nominal capacity (mAh)	25
Diameter (mm)	4.2
Total height (mm)	25.9
Discharging temperature range (°C)	-30 to +80
Weight (g)	0.6

DISCHARGE TEMPERATURE CHARACTERISTICS

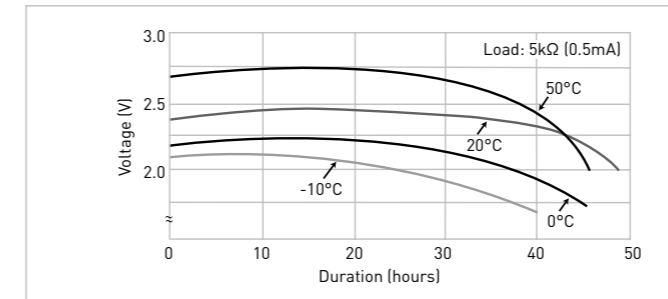

OPERATING VOLTAGE VS. DISCHARGE CURRENT*1

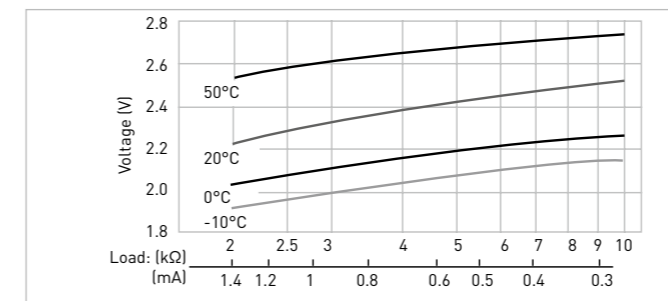

CAPACITY VS. LOAD RESISTANCE

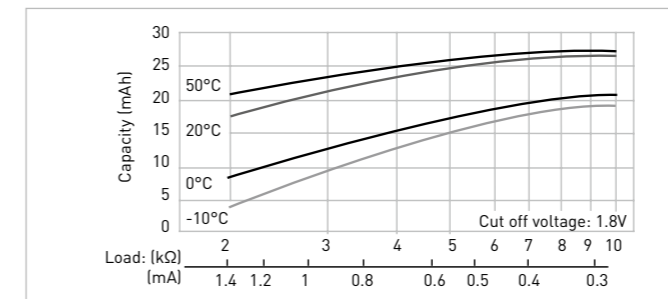

BR-435

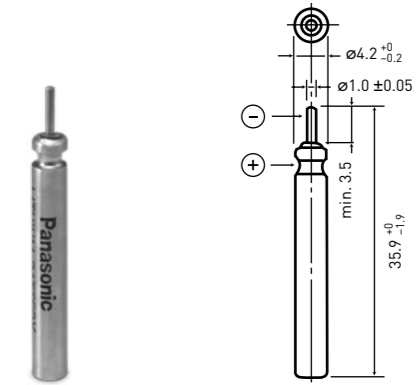

Model number	BR-435
Nominal voltage (V)	3
Nominal capacity (mAh)	50
Diameter (mm)	4.2
Total height (mm)	35.9
Discharging temperature range (°C)	-30 to +80
Weight (g)	0.9

DISCHARGE TEMPERATURE CHARACTERISTICS

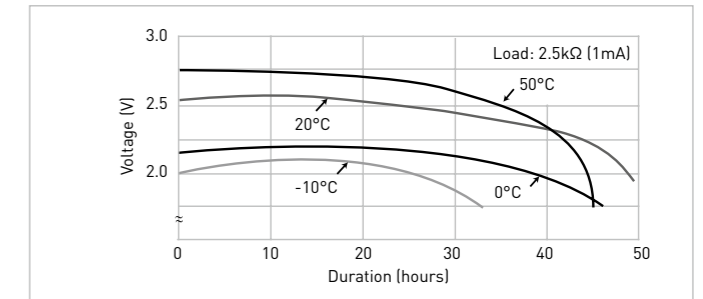

OPERATING VOLTAGE VS. DISCHARGE CURRENT*1

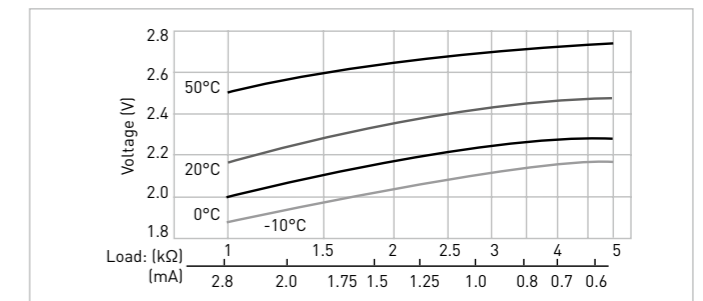

CAPACITY VS. LOAD RESISTANCE

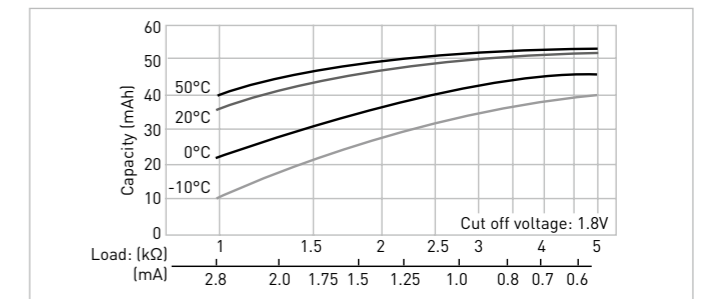

The data in this document are for descriptive purposes only and are not intended to make or imply any guarantee or warranty.

*1 Based on standard drain and cut off voltage down to 2.0V at 20°C.
*2 The illustration shows only one example of Lithium battery structure.

The data in this document are for descriptive purposes only and are not intended to make or imply any guarantee or warranty.
*1 Voltage at 50% discharge depth.

LITHIUM RECHARGEABLE COIN BATTERIES WITH REMARKABLE CHARACTERISTICS



VIDEO



Scan QR code to view product series video.

Panasonic rechargeable Lithium coin batteries are designed chiefly for memory back-up applications such as computers, fax machines or data terminals. They stay reliable through many charge-discharge cycles, boast a very low self-discharge rate and deliver superior long-term reliability.



VANADIUM RECHARGEABLE LITHIUM BATTERIES (VL SERIES) – COIN TYPE RECHARGEABLE LITHIUM BATTERIES

These high quality Lithium coin batteries feature vanadium oxide for the positive pole, Lithium alloy for the negative pole and a non-aqueous solvent for the electrolyte.

FEATURES

- ⦿ Rechargeable Lithium technology
- ⦿ Self discharge rate at 20°C is only 2.0% per year
- ⦿ 1,000 charge-discharge cycles at 10% depth of discharge
- ⦿ Superior long-term reliability
- ⦿ Years of experience in production

APPLICATIONS

- ⦿ Real Time Clock (RTC)
- ⦿ Tracking & RFID
- ⦿ Remote Keyless Entry (RKE)
- ⦿ Fax machines
- ⦿ Remote control
- ⦿ Mobile phones, etc.

Model number	Electrical characteristics at 20°C		Dimensions with tube (mm)		Approx. weight (g)	IEC
	Nominal voltage (V)	Nominal*1 capacity (mAh)	Diameter	Total height		
VL-621*2	3	1.5	6.8	2.1	0.3	-
VL-1220*2	3	7.0	12.5	2.0	0.8	-
VL-2020*2	3	20.0	20.0	2.0	2.2	-
VL-2320*2	3	30.0	23.0	2.0	2.7	-
VL-2330*2	3	50.0	23.0	3.0	3.5	-
VL-3032*2	3	100.0	30.0	3.2	6.2	-

3D ILLUSTRATION*3

- 1 Negative pole
- 2 Anode (Lithium Aluminium alloy)
- 3 Separator
- 4 Gasket
- 5 Positive pole (cell can)
- 6 Cathode (Vanadium Pentoxide)

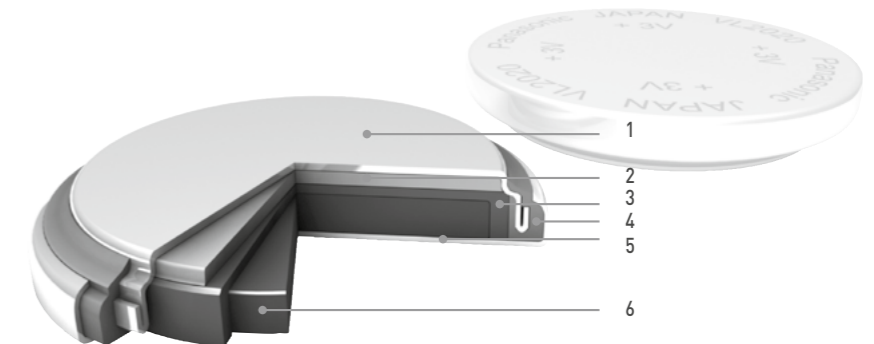

The data in this document are for descriptive purposes only and are not intended to make or imply any guarantee or warranty.

*1 Based on standard drain and cut off voltage down to 2.0V at 20°C.

*2 Only battery with terminal are handled.

*3 The illustration shows only one example of Lithium battery structure.

CHARGING

Charging circuits

Charging/discharging cycle	Approx. 1,000 times at 10% discharge depth to nominal capacity
Charging system*1	Constant-voltage charging. (Please strictly adhere to the specified charge voltage)
Operating temperature	-20°C to +60°C

The charging circuit is crucial in terms of ensuring that full justice will be done to the battery characteristics. Consider it carefully as the wrong charging circuit can cause trouble.

Precautions regarding the charge voltage setting

Under no circumstances should constant current charging, which is used for Nickel-Cadmium batteries, be used. Ignoring this precaution will cause the battery voltage to rise to about 5V, resulting in a deterioration of performance.

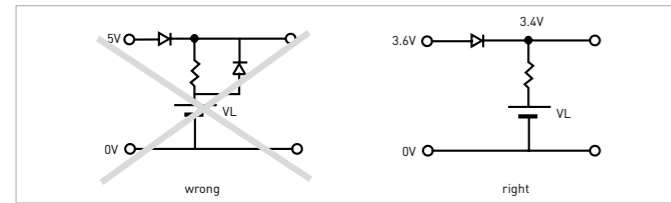

Charge voltage range

If a fixed-charging method is applied, please adhere to the specified charging voltage. The guaranteed value over an operating temperature range from -20°C to +60°C is 3.4V ± 0.15V. (Actual value: 3.4V ± 0.20V)

- If the charging voltage exceeds the specifications, the internal resistance of the battery will rise and may cause battery deterioration. Also, with a charge voltage around 4V, corrosion of the (+) terminal (case) may occur, causing leakage.
- It is not possible for the battery capacity to recover completely when the charging voltage is below the specification.

Recommended charging circuits - basic conditions

Charge voltage:	3.4V ± 0.15V
Charge current:	For a battery voltage of 3V
VL-621	Approx. 0.2mA or below
VL-1220	Approx. 0.5mA or below
VL-2020	Approx. 1.5mA or below
VL-2320, VL-2330	Approx. 2.0mA or below

VL-3032 Approx. 4.0mA or below
 (It is permissible for the current to increase beyond the above level when the battery voltage drops below 3V.)

Mixed usage of batteries

Do not use these batteries and Lithium primary batteries or other rechargeable batteries together, and do not use new batteries and old batteries together even if they are of the same type.

Influence of the charge voltage on VL batteries

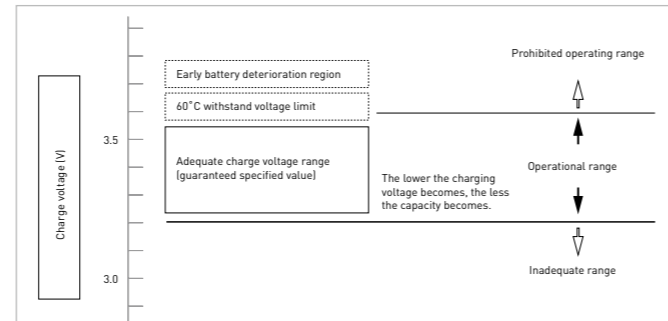

If the charge voltage goes beyond its adequate range, battery performance may deteriorate early. Be sure to observe the guaranteed charge voltage.

VL cycle life

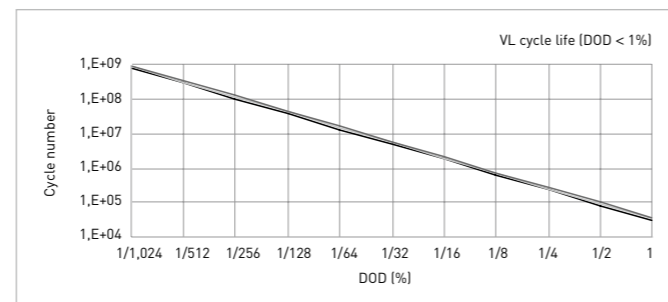
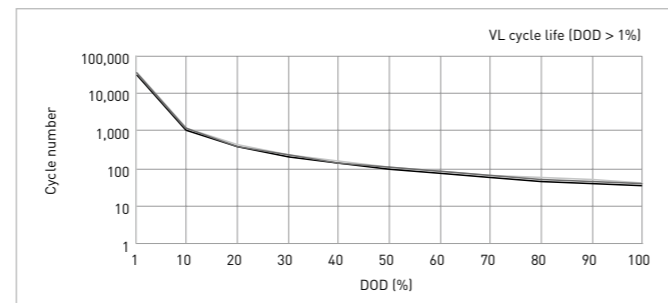

Reference: Examples of charging circuits

Patent acquired

Standard circuits
 D₂: select a diode of small inverse current (I_R=1μA below/5V)
 D₁, D₂: MA3X716 (Diode type code)
 D₃: MA3X704, MA2J728

	R ₁	R ₂	Charge current (max.)
VL-621	2.2kΩ	5.6kΩ	0.2mA
VL-1220	750Ω	1.8kΩ	0.5mA
VL-2020	200Ω	510Ω	1.5mA
VL-2320, VL-2330	150Ω	390Ω	2.0mA
VL-3032	68Ω	180Ω	4.0mA

Patent acquired

Simple economical circuits
 D: MA2J728 (Very small reverse current)

Load with 5V applied	1mA below	
	D, Vf	0~0.30V
	R ₁	R ₂
VL-621	6.2kΩ	2.4kΩ
VL-1220	1500Ω	560Ω
VL-2020	470Ω	180Ω
VL-2320, VL-2330	390Ω	150Ω
VL-3032	180Ω	68Ω

Vf of D will be different from the value given above if a current in excess of 1mA flows to the load during operation. Compensation must be provided by the resistors in such cases.

	ZD	D ₁	R ₁	
A	MAZ30360L	MA3X704	300Ω	Common to all types
B	MAZ30360H	MA2J728	270Ω	

Type	VL-3032	VL-2330	VL-2320	VL-2020	VL-1220	VL-621
R ₂ A	Not required				470Ω	1.5kΩ
R ₂ B	Not required				560Ω	1.6kΩ

D₂: select a diode of small inverse current (I_R=1μA below/5V)

For minimizing current leakage due to resistance, etc., as when charging by another battery.

REG	D
3.7V	MA2J728

For details, refer to the constant voltage element specifications.

VL-621

DIMENSIONS (MM)

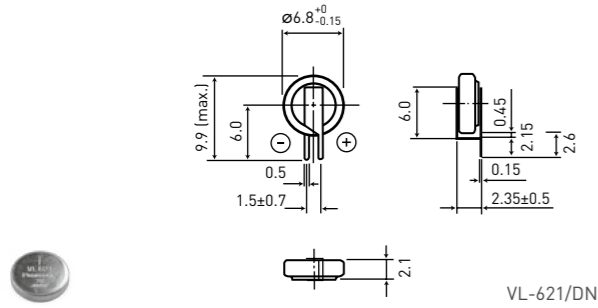

VL-621/DN

Model number	VL-621
Nominal voltage (V)	3
Nominal capacity (mAh)	1.5
Diameter (mm)	6.8
Total height (mm)	2.1
Discharging temperature range (°C)	-20 to +60
Weight (g)	0.3

DISCHARGE TEMPERATURE CHARACTERISTICS

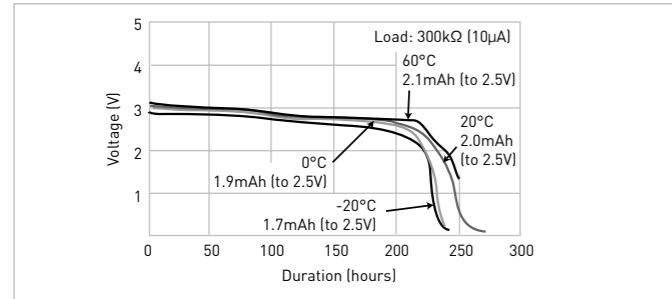

CONSUMPTION CURRENT VS. DURATION TIME

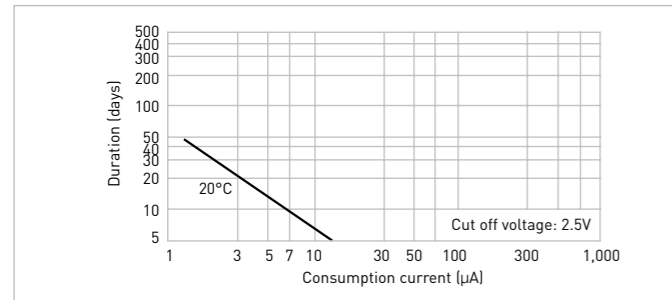

VL-1220

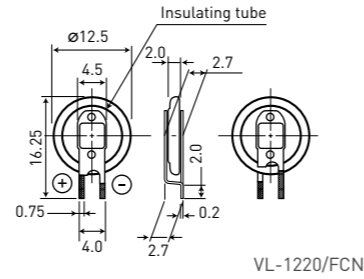

VL-1220/FCN

Model number	VL-1220
Nominal voltage (V)	3
Nominal capacity (mAh)	7.0
Diameter (mm)	12.5
Total height (mm)	2.0
Discharging temperature range (°C)	-20 to +60
Weight (g)	0.8

DISCHARGE TEMPERATURE CHARACTERISTICS

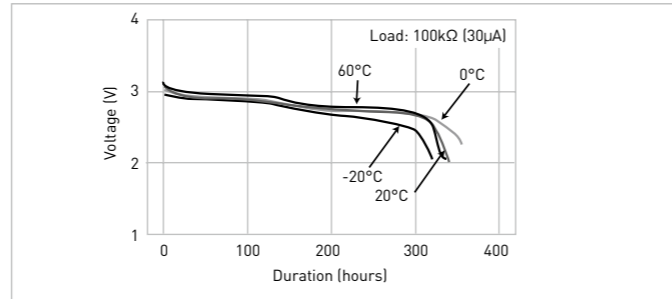

CONSUMPTION CURRENT VS. DURATION TIME

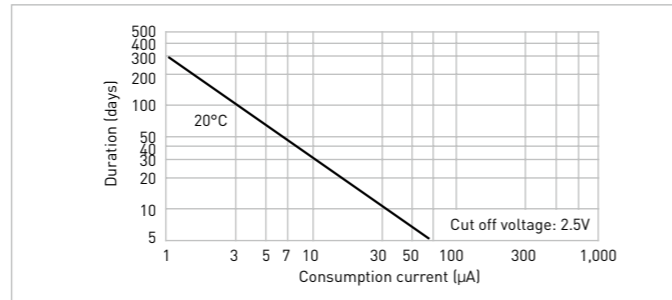

VL-2020

DIMENSIONS (MM)

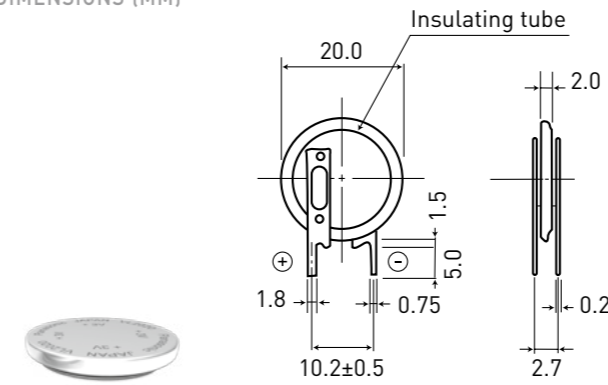

Model number	VL-2020
Nominal voltage (V)	3
Nominal capacity (mAh)	20.0
Diameter (mm)	20.0
Total height (mm)	2.0
Discharging temperature range (°C)	-20 to +60
Weight (g)	2.2

DISCHARGE TEMPERATURE CHARACTERISTICS

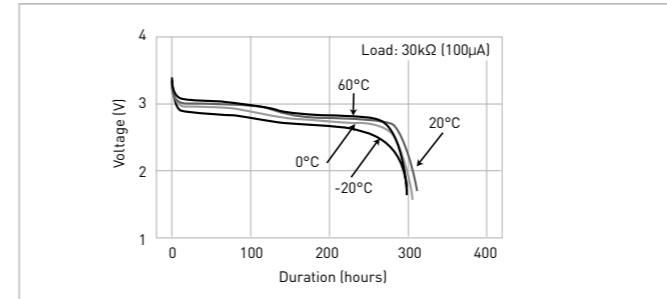

CONSUMPTION CURRENT VS. DURATION TIME

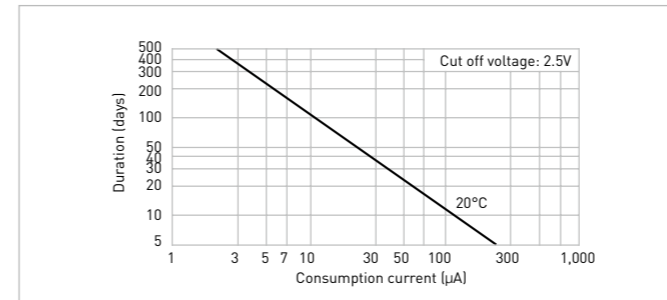

VL-2320

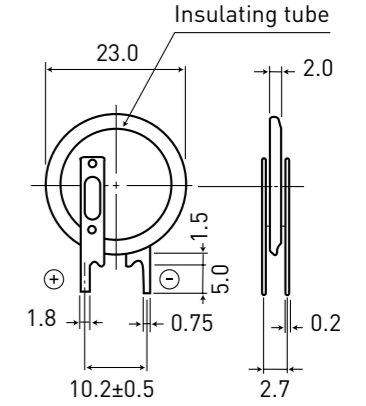

Model number	VL-2320
Nominal voltage (V)	3
Nominal capacity (mAh)	30.0
Diameter (mm)	23.0
Total height (mm)	2.0
Discharging temperature range (°C)	-20 to +60
Weight (g)	2.7

DISCHARGE TEMPERATURE CHARACTERISTICS

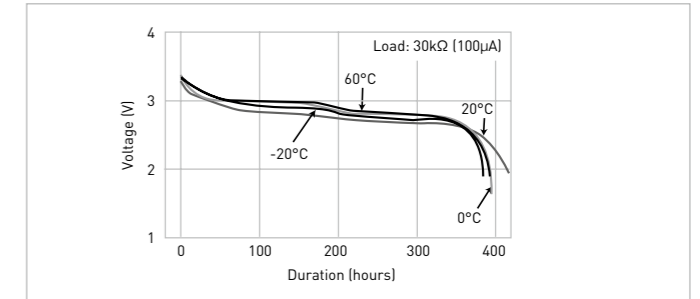

CONSUMPTION CURRENT VS. DURATION TIME

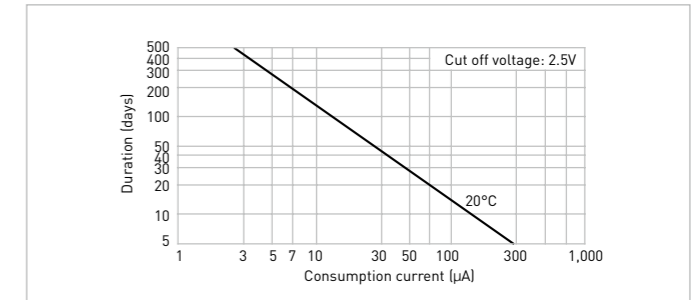

VL-2330

DIMENSIONS (MM)

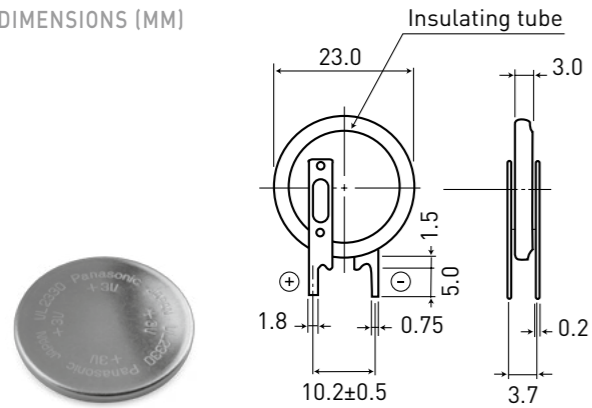

Model number	VL-2330
Nominal voltage (V)	3
Nominal capacity (mAh)	50.0
Diameter (mm)	23.0
Total height (mm)	3.0
Discharging temperature range (°C)	-20 to +60
Weight (g)	3.5

DISCHARGE TEMPERATURE CHARACTERISTICS

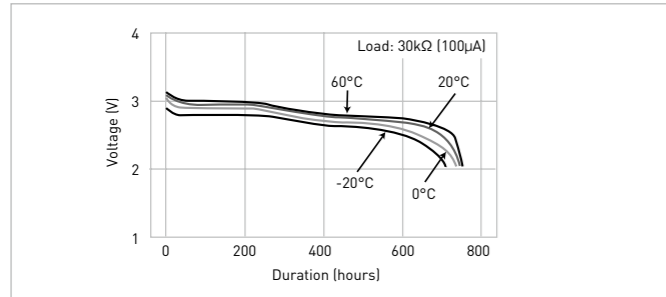

CONSUMPTION CURRENT VS. DURATION TIME

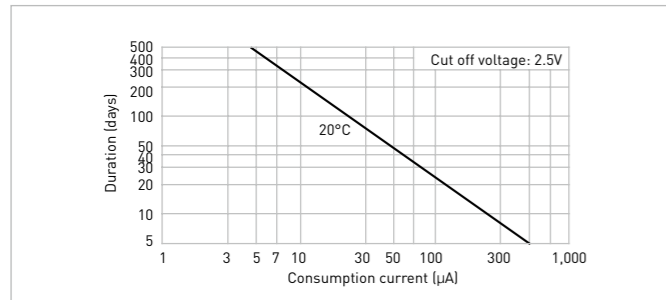

VL-3032

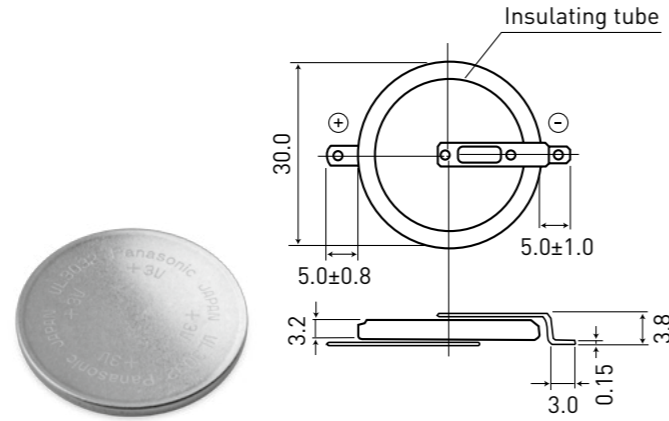

Model number	VL-3032
Nominal voltage (V)	3
Nominal capacity (mAh)	100.0
Diameter (mm)	30.0
Total height (mm)	3.2
Discharging temperature range (°C)	-20 to +60
Weight (g)	6.2

DISCHARGE TEMPERATURE CHARACTERISTICS

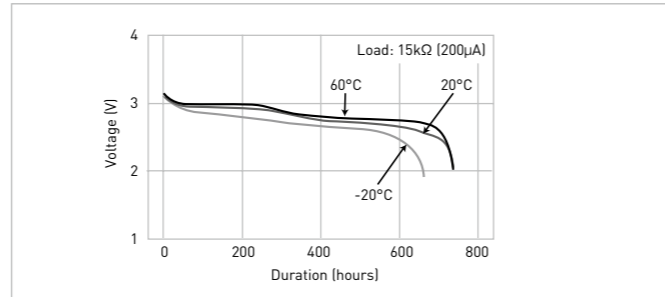

CONSUMPTION CURRENT VS. DURATION TIME

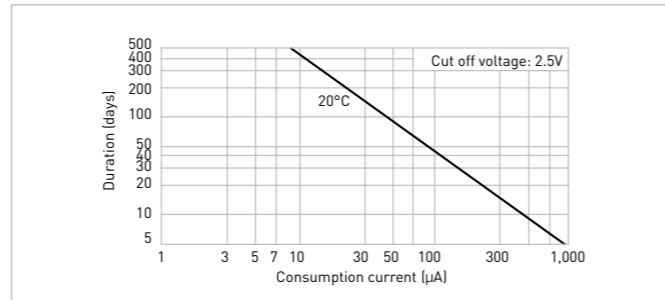

MANGANESE RECHARGEABLE LITHIUM BATTERIES (ML SERIES) - COIN TYPE RECHARGEABLE LITHIUM BATTERIES

These super compact rechargeable Lithium batteries feature a Manganese compound oxide for the positive electrode, a Lithium/Aluminum alloy for the negative electrode and a special non-aqueous solvent for the electrolyte. They can easily be incorporated into circuits where 3V ICs are used to save space.

FEATURES

- Rechargeable Lithium technology
- Self discharge rate at 20°C is only 2.0% per year
- 1,000 charge-discharge cycles at 10% depth of discharge
- Superior long-term reliability
- Years of experience in production

APPLICATIONS

- Fax machine
- Memory back-up power supplies for mobile phones
- Tracking & RFID
- Pagers and other compact communications equipment
- Real Time Clock (RTC), etc.

Model number	Electrical characteristics at 20°C		Dimensions with tube (mm)		Approx. weight (g)	IEC
	Nominal voltage (V)	Nominal*1 capacity (mAh)	Diameter	Total height		
ML-421	3	2.3	4.8	2.1	0.1	-
ML-614	3	3.4	6.8	1.4	0.2	-
ML-621	3	5.0	6.8	2.1	0.2	-
ML-920	3	11.0	9.5	2.0	0.4	-
ML-1220	3	17.0	12.5	2.0	0.8	-
ML-2020	3	45.0	20.0	2.0	2.2	-

CHARGING

Charging circuits

Charging/discharging cycle	Approx. 1,000 times at 10% discharge depth to nominal capacity
Charging system*1	Constant-voltage charging. (Please strictly adhere to the specified charge voltage)
Operating temperature	-20°C to +60°C

The charging circuit is crucial in terms of ensuring that full justice will be done to the battery characteristics. Consider it carefully as the wrong charging circuit can cause trouble.

Precautions regarding the charge voltage setting

Under no circumstances should constant current charging, which is used for Nickel-Cadmium batteries, be used. Ignoring this precaution will cause the battery voltage to rise to about 5V, resulting in a deterioration of performance.

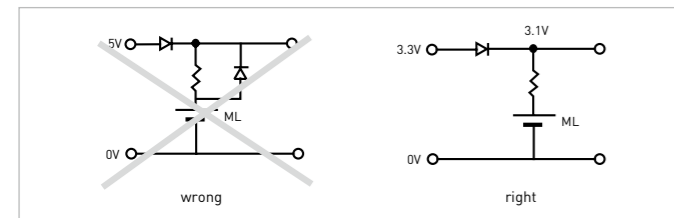

Charge voltage range

If a fixed-charging method is applied, please adhere to the specified charging voltage. Guaranteed voltage is 2.8V to 3.2V at the temperature of -20°C to +60°C.

- If the charging voltage exceeds the specifications, the internal resistance of the battery will rise and may cause battery deterioration. Also, with a charge voltage around 4V, corrosion of the ⊕ terminal (case) may occur, causing leakage.
- It is not possible for the battery capacity to recover completely when the charging voltage is below the specification.

Recommended charging circuits - basic conditions

Fixed-voltage charge

Charge voltage:	2.8 to 3.2V (Standard voltage: 3.1V)
Charge current:	For a battery voltage of 2.5V
ML-421	Approx. 0.15mA or below
ML-614	Approx. 0.3mA or below
ML-621	Approx. 0.6mA or below

ML-920, ML-1220	Approx. 1.2mA or below
ML-2020	Approx. 3.0mA or below

Mixed usage of batteries

Do not use these batteries and Lithium primary batteries or other rechargeable batteries together, and do not use new batteries and old batteries together even if they are of the same type.

Influence of the charge voltage on ML batteries

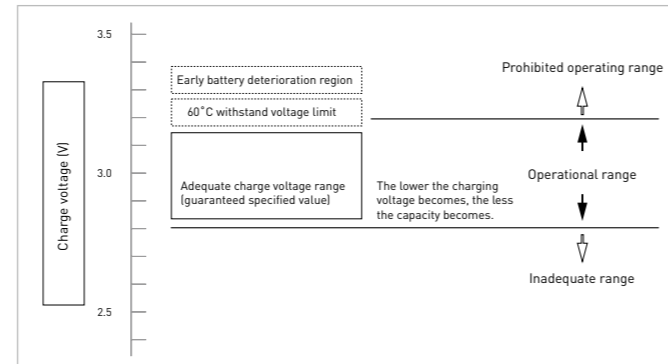

If the charge voltage goes beyond its adequate range, battery performance may deteriorate early. Be sure to observe the guaranteed charge voltage.

ML cycle life

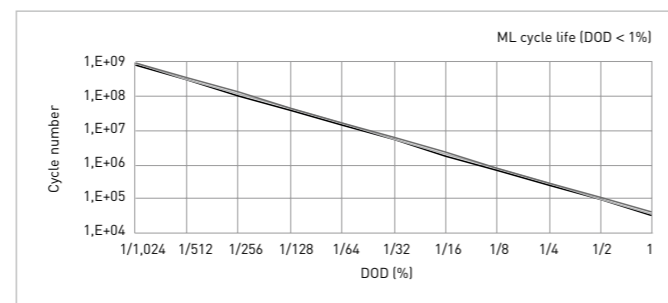
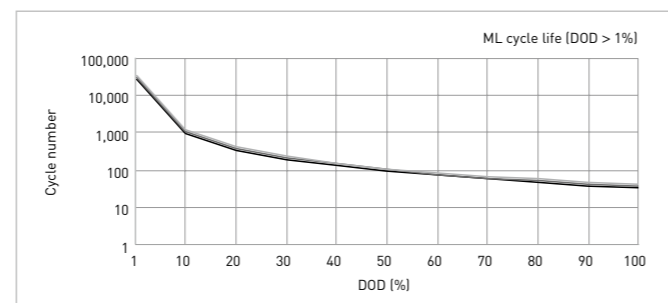

Reference: Examples of charging circuits

When charging using another battery		
REG	D	R
ML-421		
3.2V	MA2J728	6.2kΩ
3.1V	MA2J728	5.1kΩ
ML-614		
3.2V	MA2J728	1.8kΩ
3.1V	MA2J728	1.5kΩ
ML-621		
3.2V	MA2J728	910Ω
3.1V	MA2J728	750Ω
ML-920		
3.2V	MA2J728	470Ω
3.1V	MA2J728	390Ω
ML-1220		
3.2V	MA2J728	470Ω
3.1V	MA2J728	390Ω
ML-2020		
3.2V	MA2J728	180Ω
3.1V	MA2J728	150Ω

Standard circuits		
For D ₂ , select a diode of small inverse current (I _r =1μA/5V)		
D ₁ , D ₂ : MA3X716 (Diode type code)		
D ₃ : MA3X704, MA2J728		
	R ₁	R ₂
ML-421	5.1kΩ	9.1kΩ
ML-614	2.7kΩ	5.1kΩ
ML-621	1.1kΩ	2.0kΩ
ML-920	680Ω	1.3kΩ
ML-1220	680Ω	1.3kΩ
ML-2020	180Ω	330Ω

Simple economical circuits		
Load	100μA below	
D, Vf	0~0.2V	
	R ₁	R ₂
ML-421	10kΩ	5.1kΩ
ML-614	5.1kΩ	2.7kΩ
ML-621	2.4kΩ	1.3kΩ
ML-920	1kΩ	510Ω
ML-1220	1kΩ	510Ω
ML-2020	330Ω	180Ω

Vf of D will be different from the value given above if a current in excess of 10μA flows to the load during operation. Compensation must be provided by the resistors in such cases.

ML-421

DIMENSIONS (MM)

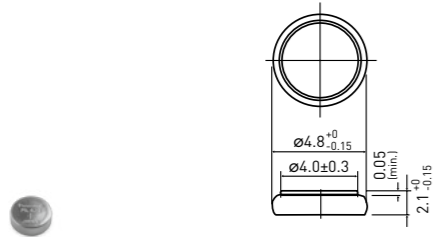

Model number	ML-421
Nominal voltage (V)	3
Nominal capacity (mAh)	2.3
Diameter (mm)	4.8
Total height (mm)	2.1
Discharging temperature range (°C)	-20 to +60
Weight (g)	0.1

DISCHARGE CHARACTERISTICS

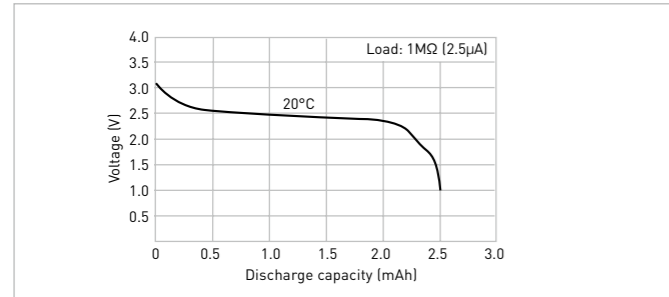

CHARGE VOLTAGE VS. DISCHARGE CAPACITY

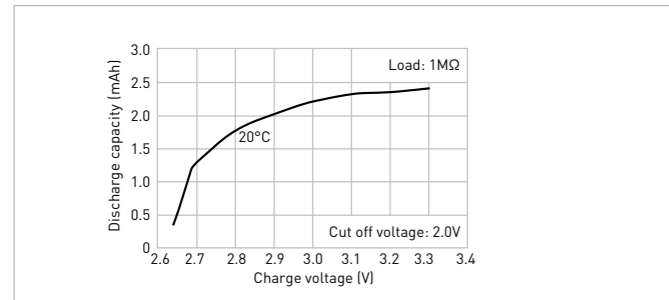

ML-614

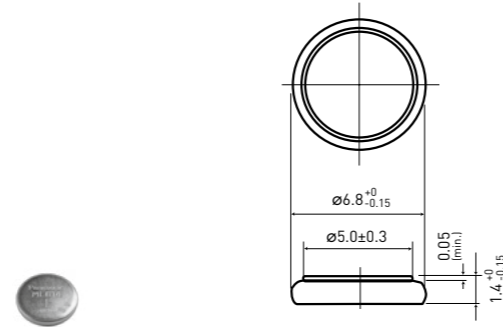

Model number	ML-614
Nominal voltage (V)	3
Nominal capacity (mAh)	3.4
Diameter (mm)	6.8
Total height (mm)	1.4
Discharging temperature range (°C)	-20 to +60
Weight (g)	0.2

DISCHARGE CHARACTERISTICS

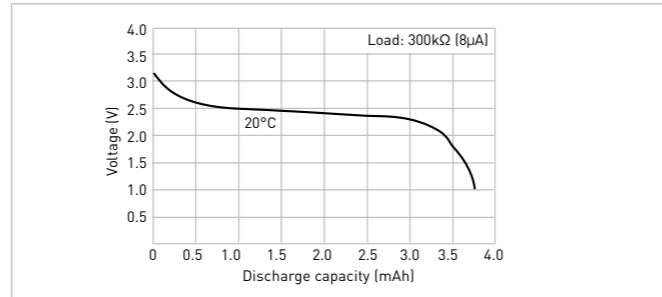

CONSUMPTION CURRENT VS. DURATION TIME

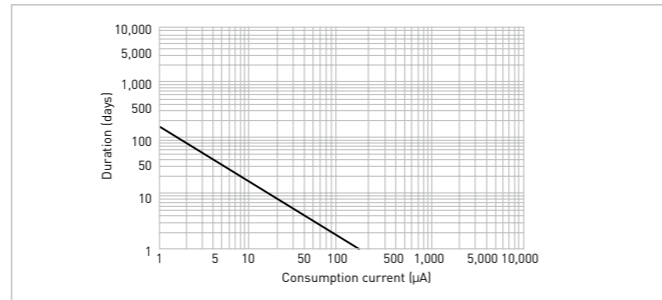

ML-621

DIMENSIONS (MM)

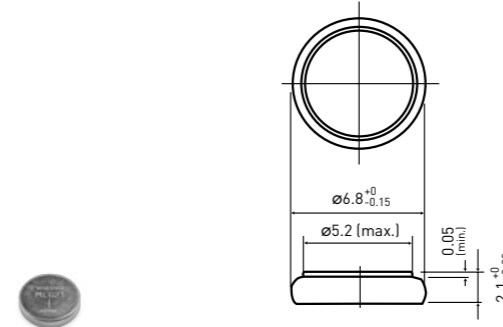

Model number	ML-621
Nominal voltage (V)	3
Nominal capacity (mAh)	5.0
Diameter (mm)	6.8
Total height (mm)	2.1
Discharging temperature range (°C)	-20 to +60
Weight (g)	0.2

DISCHARGE CHARACTERISTICS

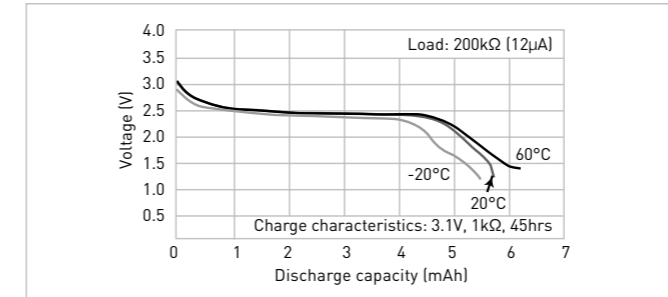

CHARGE CHARACTERISTICS

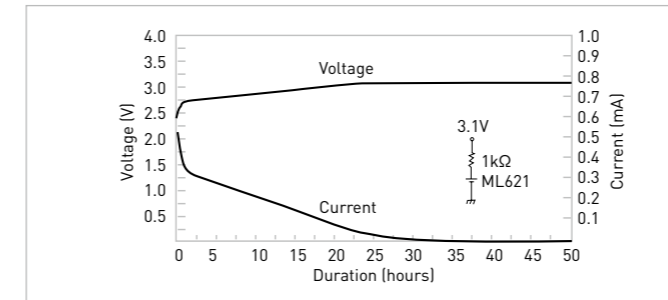

CONSUMPTION CURRENT VS. DURATION TIME

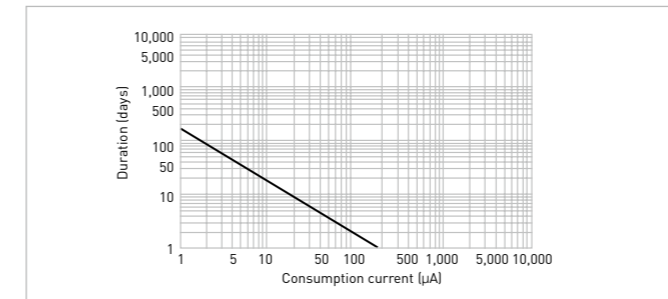

ML-920

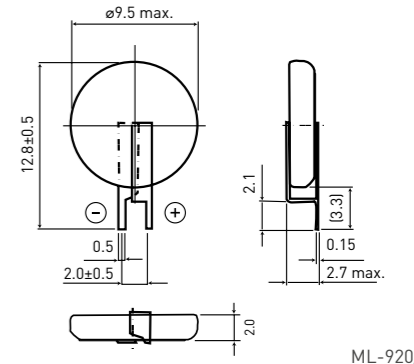

Model number	ML-920
Nominal voltage (V)	3
Nominal capacity (mAh)	11.0
Diameter (mm)	9.5
Total height (mm)	2.0
Discharging temperature range (°C)	-20 to +60
Weight (g)	0.4

DISCHARGE CHARACTERISTICS

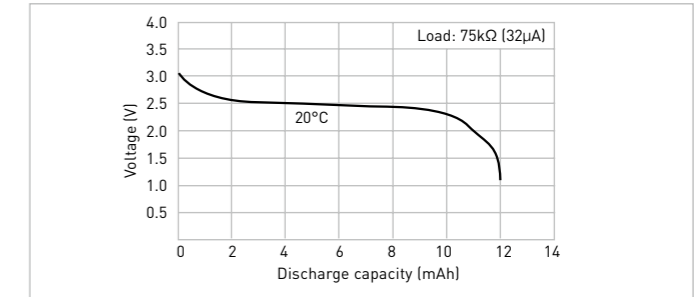

CONSUMPTION CURRENT VS. DURATION TIME

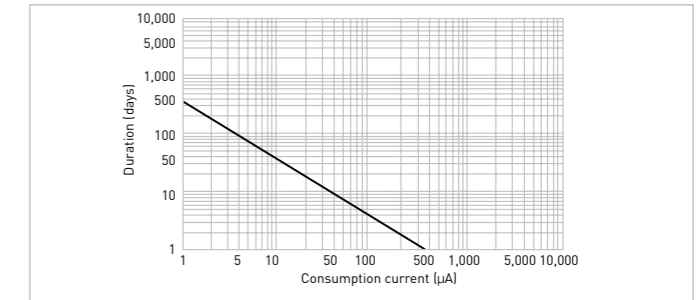

ML-1220

DIMENSIONS (MM)

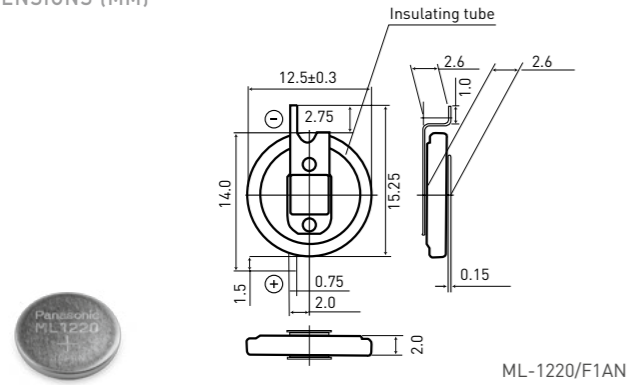

ML-1220/F1AN

ML-2020

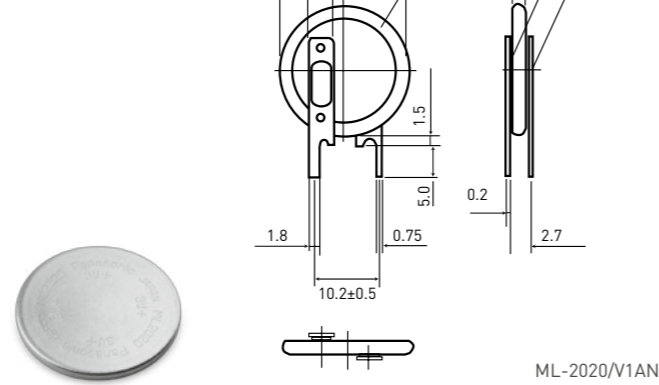

ML-2020/V1AN

Model number	ML-1220
Nominal voltage (V)	3
Nominal capacity (mAh)	17.0
Diameter (mm)	12.5
Total height (mm)	2.0
Discharging temperature range (°C)	-20 to +60
Weight (g)	0.8

Model number	ML-2020
Nominal voltage (V)	3
Nominal capacity (mAh)	45.0
Diameter (mm)	20.0
Total height (mm)	2.0
Discharging temperature range (°C)	-20 to +60
Weight (g)	2.2

DISCHARGE CHARACTERISTICS

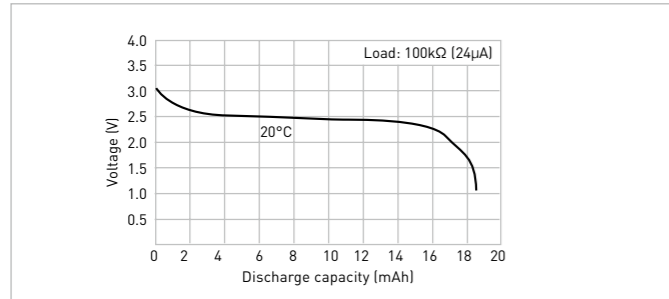

DISCHARGE CHARACTERISTICS

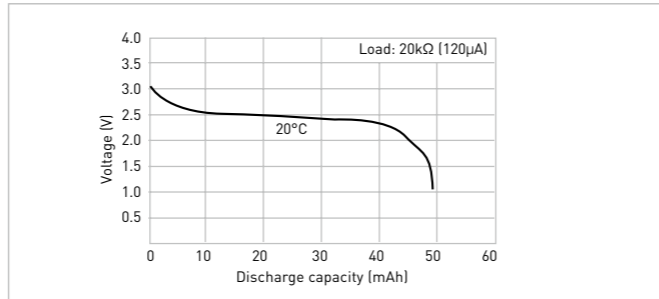

CONSUMPTION CURRENT VS. DURATION TIME

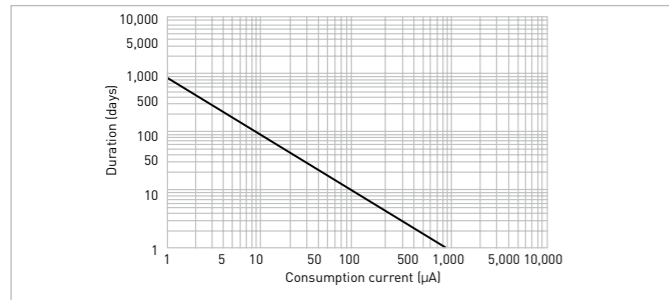

CONSUMPTION CURRENT VS. DURATION TIME

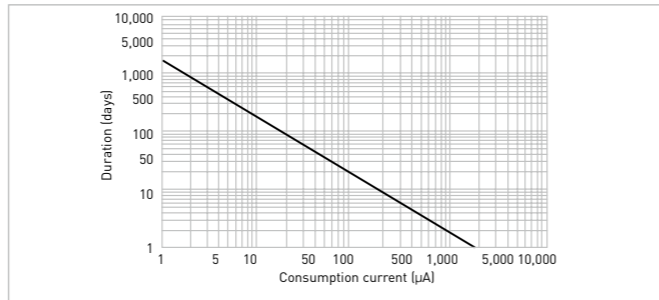

TITANIUM RECHARGEABLE LITHIUM BATTERIES (MT SERIES) – COIN TYPE RECHARGEABLE LITHIUM BATTERIES

These coin type Manganese Titanium Rechargeable Lithium coin batteries use a Lithium-Manganese complex oxide for the positive pole and a special Lithium-Titanium complex oxide for the negative pole. They provide a capacity which is more than 10 times that of capacitors of the same size.

FEATURES

- Rechargeable Lithium technology
- Superior long-term reliability
- Years of experience in production
- 500 charge-discharge cycles up to 1V or discharge limit voltage (at 100% depth of discharge)

APPLICATIONS

- Main power supplies in compact products such as rechargeable watches
- Memory back-up power supply for pagers, timers, etc.

Model number	Electrical characteristics at 20°C		Dimensions with tube (mm)		Approx. weight (g)	IEC
	Nominal voltage (V)	Nominal*1 capacity (mAh)	Diameter	Total height		
MT-516	1.5	1.8	5.8	1.6	0.2	-
MT-621	1.5	2.5	6.8	2.1	0.3	-
MT-920	1.5	5.0	9.5	2.0	0.5	-

CHARGING

Charging circuits

Charging/discharging cycle	Approx. 500 times at 100% discharge depth to nominal capacity
Charging system*1	Constant-voltage charging. (Please strictly adhere to the specified charge voltage)
Operating temperature	-10°C to +60°C

The charging circuit is crucial in terms of ensuring that full justice will be done to the battery characteristics. Consider it carefully as the wrong charging circuit can cause trouble.

Precautions regarding the charge voltage setting

Under no circumstances should constant current charging, which is used for Nickel-Cadmium batteries, be used. Ignoring this precaution will cause the battery voltage to rise to about 5V, resulting in a deterioration of performance.

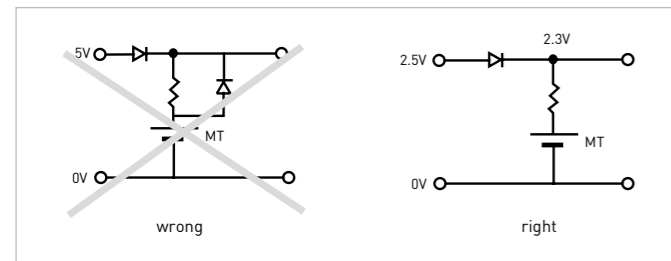

Charge voltage range

If a fixed-charging method is applied, please adhere to the specified charging voltage. Guaranteed voltage is 1.8V to 2.6V at the temperature of -10°C to +60°C.

- If the charging voltage exceeds the specifications, the internal resistance of the battery will rise and may cause battery deterioration. Also, with a charge voltage around 3V, corrosion of the ⊕ terminal (case) may occur, causing leakage.
- It is not possible for the battery capacity to recover completely when the charging voltage is below the specification.

Recommended charging circuits - basic conditions

Fixed-voltage charge

- Charge voltage: 1.8 to 2.6V (Standard voltage: 2.2V)
- Charge current: For a battery voltage of 2.3V
- MT-516 Approx. 0.36mA or below

- MT-621 Approx. 0.5mA or below
- MT-920 Approx. 1.0mA or below

Mixed usage of batteries

Do not use these batteries and Lithium primary batteries or other rechargeable batteries together, and do not use new batteries and old batteries together even if they are of the same type.

Influence of the charge voltage on MT batteries

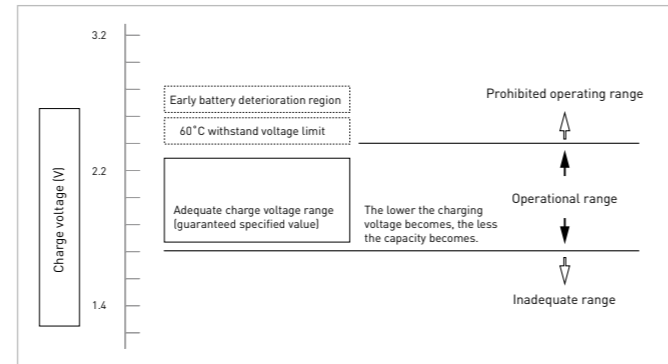

If the charge voltage goes beyond its adequate range, battery performance may deteriorate early. Be sure to observe the guaranteed charge voltage.

MT-516

DIMENSIONS (MM)

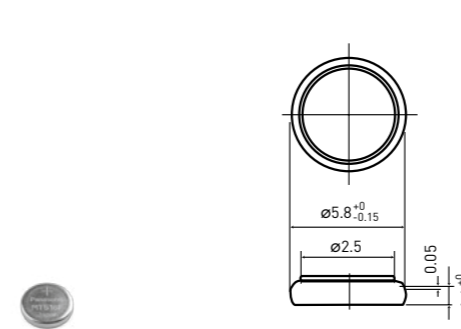

Model number	MT-516
Nominal voltage (V)	1.5
Nominal capacity (mAh)	1.8
Diameter (mm)	5.8
Total height (mm)	1.6
Discharging temperature range (°C)	-10 to +60
Weight (g)	0.2

DISCHARGE CHARACTERISTICS

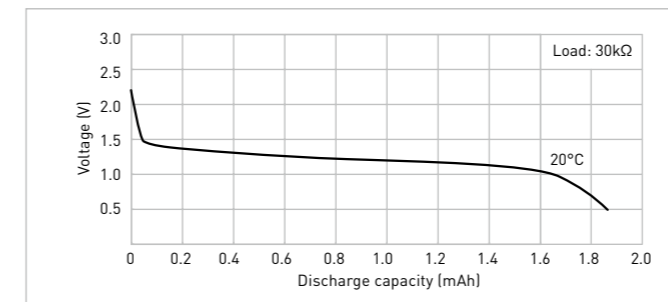

CONSUMPTION CURRENT VS. DURATION TIME

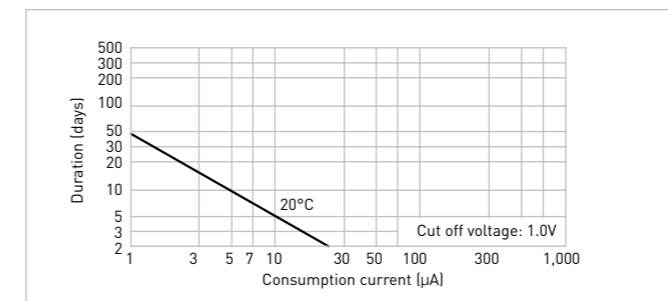

MT-621

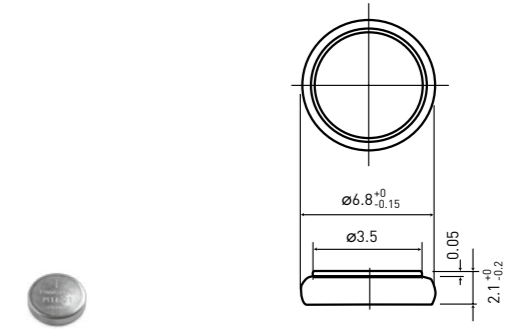

Model number	MT-621
Nominal voltage (V)	1.5
Nominal capacity (mAh)	2.5
Diameter (mm)	6.8
Total height (mm)	2.1
Discharging temperature range (°C)	-10 to +60
Weight (g)	0.3

DISCHARGE CHARACTERISTICS

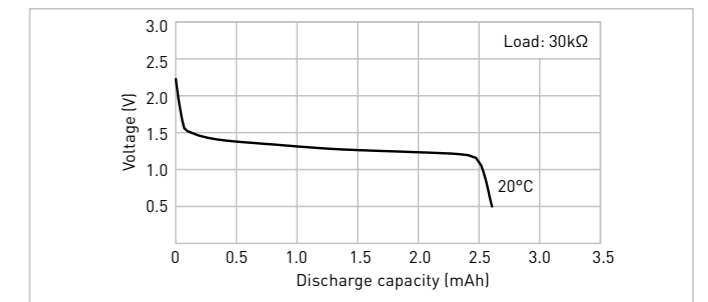

CONSUMPTION CURRENT VS. DURATION TIME

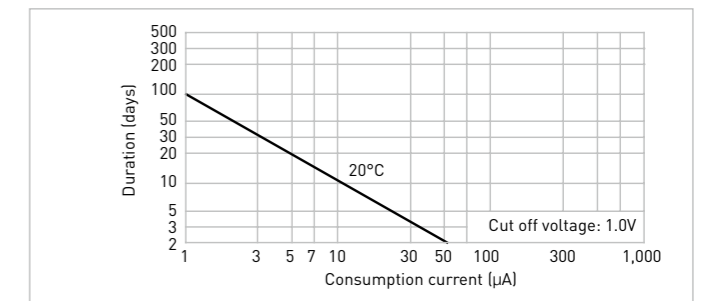

MT-920

DIMENSIONS (MM)

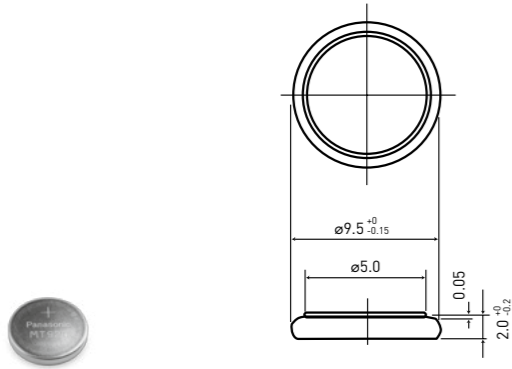

Model number	MT-920
Nominal voltage (V)	1.5
Nominal capacity (mAh)	5.0
Diameter (mm)	9.5
Total height (mm)	2.0
Discharging temperature range (°C)	-10 to +60
Weight (g)	0.5

DISCHARGE CHARACTERISTICS

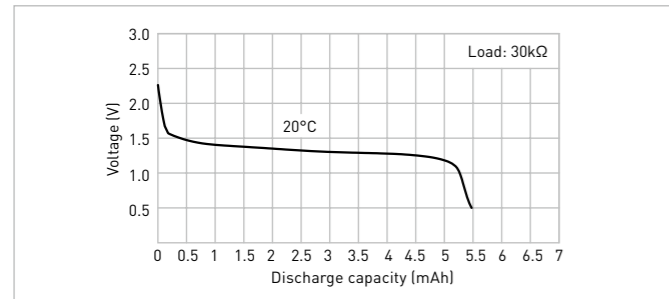

CONSUMPTION CURRENT VS. DURATION TIME

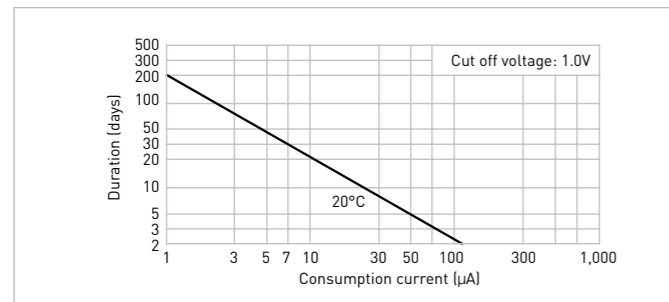

DISCHARGE TEMPERATURE CHARACTERISTICS

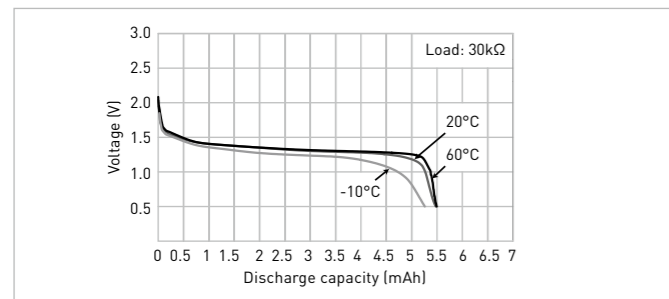

LONG-STANDING EXPERIENCE IN HIGH QUALITY WELDING AND SOLDERING METHODS



Due to Panasonic's long experience in quality welding and soldering methods, our customers can always expect the best terminal solution for their application. Our comprehensive line-up of different terminal types covers nearly every requirement – and custom-made solutions are possible as well.

BATTERY TERMINALS

Terminal welding

For terminal welding on the battery, it is quite important to establish the best welding method and its best conditions in order to keep the strong weld strength without any damages on the battery performances. Panasonic mainly use the Laser welding method which is applicable to attach terminals on even quite small batteries that the spot welding hardly to do for. Therefore, our products can correspond exactly and flexibly to various applications. Also, we have established our own high reliable welding capability with a lot of amount of testing data to search the best weld condition for each various combinations of various battery sizes and terminal shapes, which can be provided for widespread equipments and devices.

Soldering on PCB

On the edge of all terminal, Tin plating is applied for increasing the reliability of soldering instead of the solder plate in order to consider influences on environments.

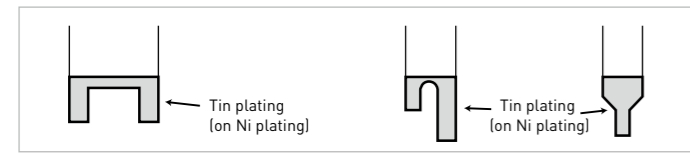

Complete Line-up

Panasonic offers a full range of batteries with terminals for various PCB mounting. Since the terminals come in a variety types, please contact Panasonic for further details. On the other hand, we also provide battery holders for some limited sizes.

SOLDERING LITHIUM BATTERIES

Using a soldering iron

Do not allow the soldering iron to make direct contact with the bodies of the batteries. Proceed with the soldering quickly within 5 seconds while maintaining the iron tip temperature at about 350°C, and do not allow the temperature of the battery bodies to exceed 85°C. (Heat resistance BR type is 125°C)

Automatic dip-soldering bath

Soldering with a dip-soldering bath can be used by condition but do not allow the temperature of the battery bodies exceed 85°C. It is important to note, depending on the temperature

conditions inside the dipping device, that the battery body temperature may rise after dipping due to the residual heat retained. When a post-dipping temperature rise is observed, review the temperature conditions and consider a dipping time reduction or a way of forcibly cooling the batteries after dipping.

Basic conditions

Solder dipping bath temperature	Not exceed 260°C
Dipping duration	Within 5 sec.
Number of dipping	Within 2 times

Cautions

Example where the terminals were soldered straight onto a coin type Lithium battery, the terminals were connected to a PC board or other electronic components, and the heat generated by the soldering adversely affected the battery, resulting in a deterioration of the battery characteristics:

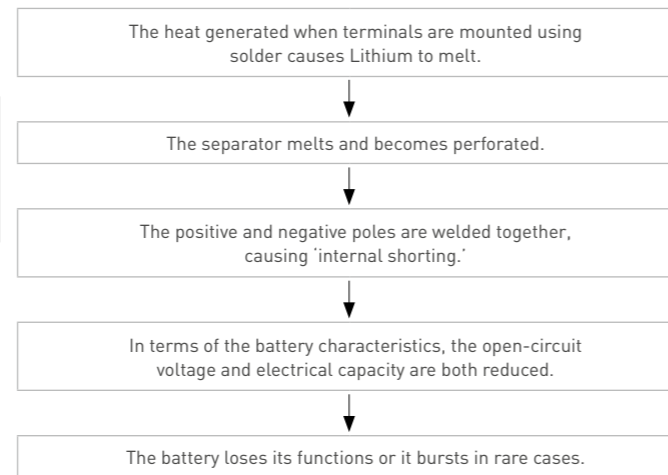

Soldering

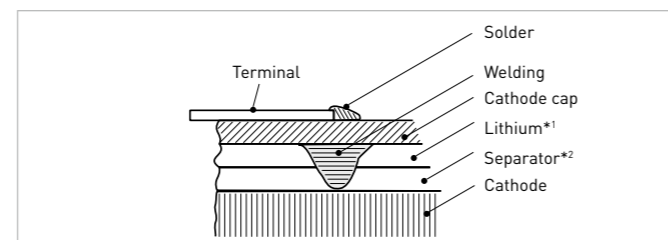

TERMINAL TYPES

Panasonic offers a broad range of different tabs for our Lithium batteries in order to meet all customer needs. In addition tailormade solutions are possible as well.

H TYPE

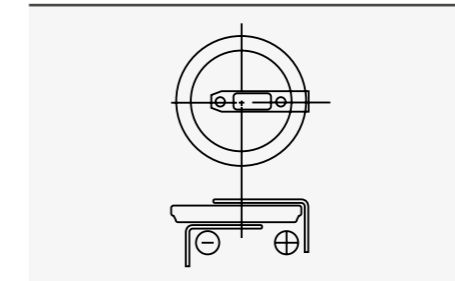

V TYPE

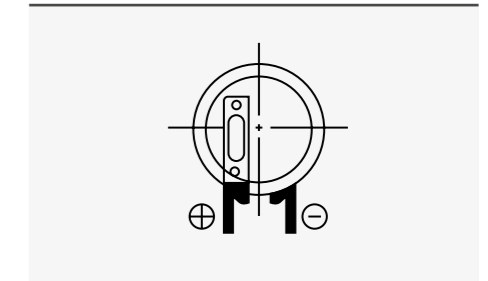

G TYPE

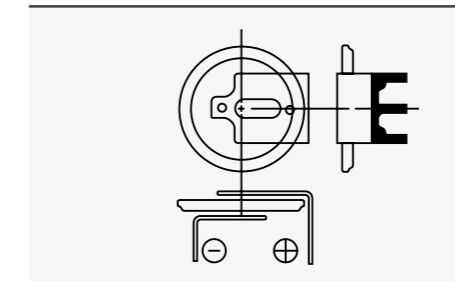

T TYPE

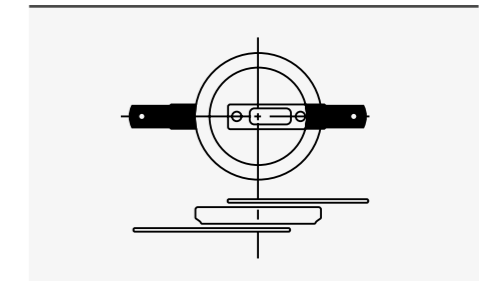

F TYPE

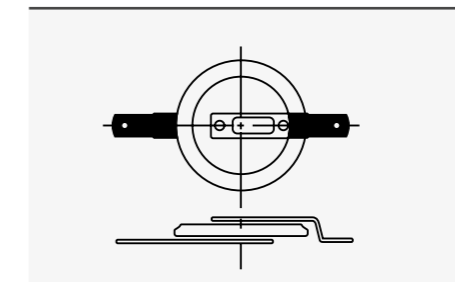

S TYPE

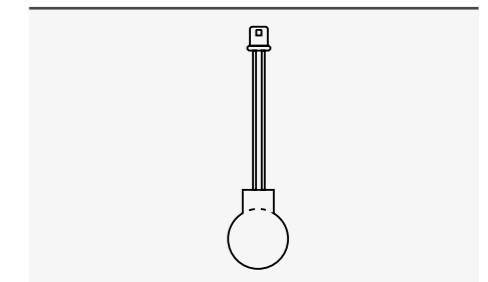

BR-1/2A With axial pin terminal

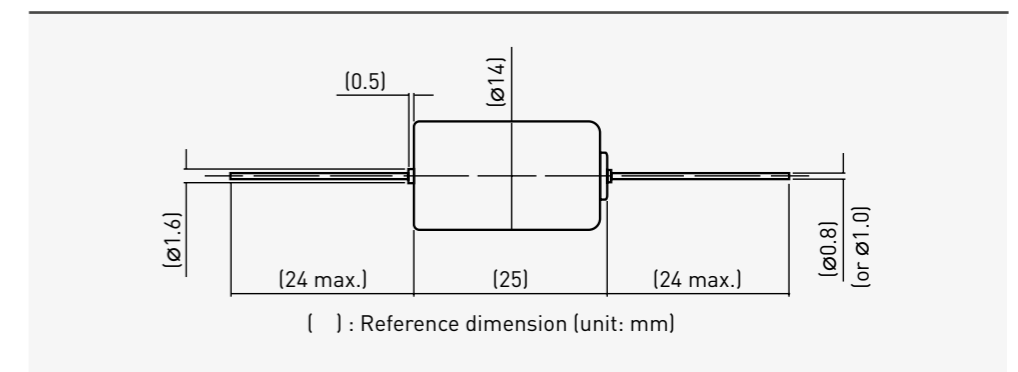

The data in this document are for descriptive purposes only and are not intended to make or imply any guarantee or warranty.

*1 Metal whose melting point is about 180°C

*2 Non woven cloth of polypropylene whose melting point is about 165°C

PRODUCT CERTIFICATIONS

UL approved batteries

All our Lithium batteries are in compliance with UL 1642 (primary and secondary lithium batteries) - file number MH 12210. These requirements cover lithium batteries intended for use in technician-replaceable or user-replaceable applications.

FACTORY CERTIFICATIONS

All our production sites are ISO 9001 und ISO 14001 certified. Moriguchi, Japan and Jakarta, Indonesia sites are additionally certified towards TS 16949. Moriguchi, Japan is also certified according to OHSAS 18001.

APPLICABLE STANDARDS

IEC 60086-1

Standardization of primary batteries with respect to their electrochemical system, dimensions, nomenclature, terminal configurations, markings, test methods, typical performance, safety and environmental aspects.

Applicable products in this catalogue: BR-2/3A [BR17335], BR-2/3AG [BR17335], CR-2 [CR15H270], CR-123A [CR17345], 2CR-5 [2CR5], CR-P2 [CRP2], BR-1225 [BR1225], BR-2325 [BR2325], CR-1025 [CR1025], CR-1216 [CR1216], CR-1220 [CR1220], CR-1616 [CR-1616], CR-1620 [CR1620], CR-2012 [CR2012], CR-2016 [CR2016], CR-2025 [CR2025], CR-2032 [CR2032], CR-2330 [CR2330], CR-2354 [CR2354], CR-2450 [CR2450], CR-3032 [CR3032]

IEC 60086-2

Complements the general information and requirements of IEC 60086-1.

IEC 60086-3

Specifies dimensions, designation, methods of tests and requirements for primary batteries for watches.

Applicable products in this catalogue:

BR-1225 [BR1225], BR-2325 [BR2325], CR-1025 [CR1025], CR-1216 [CR1216], CR-1220 [CR1220], CR-1616 [CR-1616], CR-1620 [CR1620], CR-2012 [CR2012], CR-2016 [CR2016],

CR-2025 [CR2025], CR-2032 [CR2032], CR-2330 [CR2330], CR-2354 [CR2354], CR-2450 [CR2450]

IEC 60086-4

Requirements for primary lithium batteries to ensure their safe operation under intended use and reasonably foreseeable misuse.

Applicable products in this catalogue: BR, CR

LITHIUM BATTERY TRANSPORTATION

The transportation of lithium batteries is regulated by the International Air Transport Association (IATA), the International Civil Aviation Organization (ICAO) and Accord européen relatif au transport international des marchandises Dangereuses par Route (ADR).

All batteries are approved in accordance to UN Spezial Provision SP 188 Manual of Tests & Criteria Part III Subsection 38.3.

Transport test related to UN 38.3 Revision 5 Amendment 2 reports are available on request.

Transport by road/rail

UN 3090 takes place under ADR/RID 2015.

Transport by sea

UN 3090 takes place under IMDG Code 2014.

Transport by air

UN 3090 takes place under IATA DGR 2015 56th Edition.

SECURITY EXPORT CONTROL

'Security export control' entails observing the legislation provided to maintain international peace and safety by preventing the proliferation of weapons of massive destructions (nuclear weapons, chemical warfare weapons, biological weapons and missiles) and the excessive buildup of conventional weapons. COCOM, the committee that imposed controls on exports to the Communist bloc, was disbanded on March 31, 1994. Later, as part of a new export control regime, Russia

and Eastern European countries joined with the previously affiliated nations of COCOM (Japan, America and Europe) and established the Wassenaar Arrangement for dual-use goods & technologies related to conventional weapons. According to the Export Trade Control Order revised by the Japanese Ministry of Economy, Trade & Industry in May 2008, batteries listed in this catalog are classified as 'batteries' not 'cells', and will therefore not be controlled by (7) in annex Table 1 to the Order. The above notwithstanding, these batteries may be subject to the regulations depending on their ultimate destination, application and other conditions. When a certificate of classification is required for exportation, etc. or if you have any queries, contact a Panasonic sales representative.

AVOIDING HAZARDS

Case Study and Explanation

To store batteries, place each of the batteries in the sections provided on the designated tray in such a way that they will not make contact with one another.

Ignition

2,000 new batteries were taken out from the 20-piece tray containers and thrown randomly into a cardboard box where they were stacked on top of one another. About 30 minutes later, smoke was seen emanating from the batteries followed by ignition several minutes after that.

Case study: Ignition of batteries stacked together

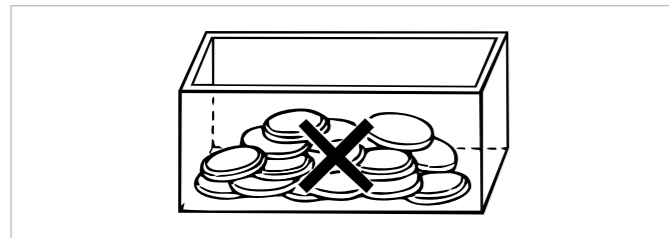

Rupture

This particular case involves batteries which were packed in trays and destined for OEMs. The batteries were packed in an intermediate package consisting of 10 trays with each tray containing 20 (or 40) batteries, and the trays were stacked on top of each other. The intermediate package (of the 10 trays) was opened at the distribution stage of our operations, and five of the trays were delivered to one customer. Since the trays were stored at an angle inside the box, the batteries fell out of their positions on the trays and became stacked up on the bottom inside the small box. As a result, some of the batteries burst.

Case study: Bursting of batteries stacked on top of one another

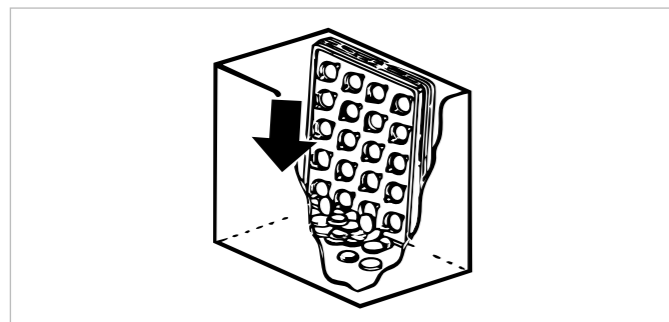

Generating Heat

21 cylindrical type Lithium batteries with tab terminals were placed in a 20-piece tray – one battery more than the capacity of the 20-piece tray. Two of the batteries were placed together with their poles reversed. As a result, the tab terminals came into contact with each other, causing external shorting, and the temperature of the two batteries rose dramatically, generating heat and causing the tubes to burst.

Since two batteries were placed in a space (indicated by the arrow) allocated to one battery, their terminals made contact with each other, and external shorting resulted.

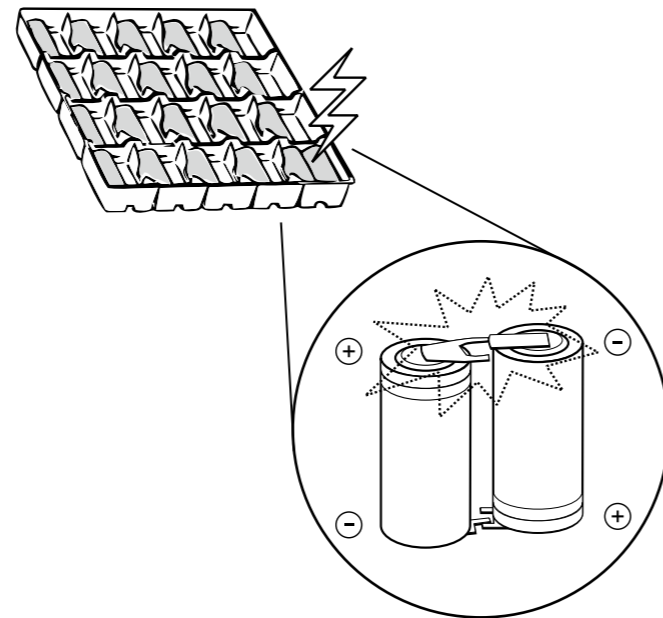

Generating heat and deterioration of capacity

To store batteries, place each of the batteries in the sections provided on the designated tray in such a way that they will not make contact with one another.

PREVENTING QUALITY PROBLEMS

Reduction of battery voltage and deterioration of capacity

(1) Reduction of battery voltage and deterioration of capacity through contact with antistatic conductive materials

Incidents have been reported where terminal-mounted batteries for memory back-up or coin type Lithium batteries have come into contact with antistatic conductive materials, thus forming external discharge circuits and leading to voltage drops or capacity deterioration.

In manufacturing plants using ICs, LSI and other semiconductor components, thoroughgoing antistatic measures are taken. Various protective materials are used to prevent static: most of them have special compounds of carbon, aluminum foil and other metals and are therefore conductive. These protective materials are used, for example, in the form of packaging bags, trays, mats, sheets, films, corrugated boards and resin cases.

A protective material may have a resistance ranging from 103 to 106Ω/cm, for instance. This means that if the ⊕ and ⊖ terminals of a battery come into contact with this material, a current ranging from several milliamperes to several microamperes will flow and the battery will discharge, causing voltage drop and capacity deterioration.

When batteries are to be used near protective materials, take every possible care to ensure that the ⊕ and ⊖ terminals of the batteries or PC boards, etc. on which batteries are mounted do not touch these protective materials directly.

Fig. 1 A terminal-mounted battery was inserted into a conductive mat. The battery charge was exhausted in several days.

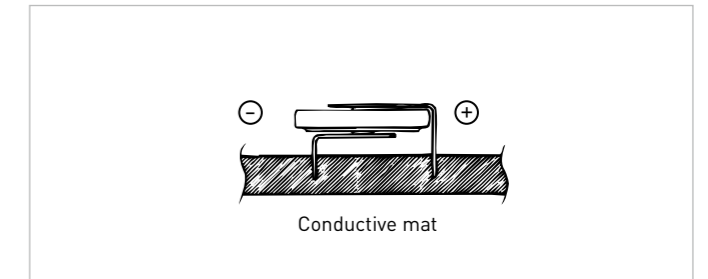

Fig. 2 Battery-mounted PC boards were inadvertently brought into contact with spacers and a conductive rubber sheet. The battery charge was exhausted.

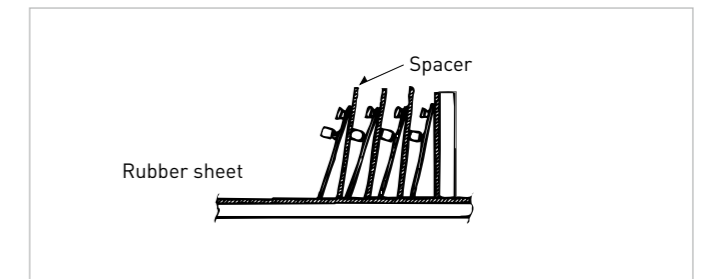
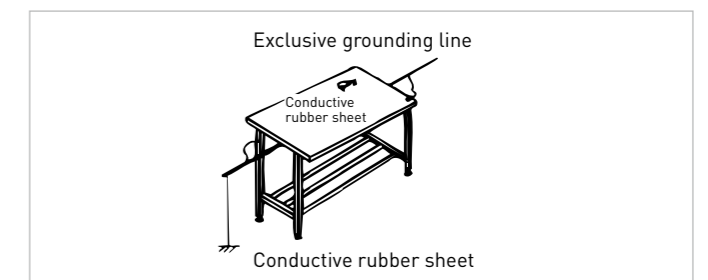

Fig. 3 A battery-mounted PC board was inadvertently brought into contact with a conductive resin case. The battery charge was exhausted.



Fig. 4 A battery was placed directly on a rubber sheet spread over a worktable. The ⊕ and ⊖ terminals were in contact with the sheet and the battery charge was exhausted.



(2) Reduction of battery voltage and deterioration of capacity through contact between batteries

Incidents have been reported where terminal-mounted batteries for memory back-up or coin type Lithium batteries have come into contact each other, thus forming discharge circuits (shorted state) and leading to voltage drops or capacity deterioration. Observe the following precautions.

1. Remove the batteries from the tray one at a time. If the tray is turned upside down, the batteries will come into contact with each other, forming discharge circuits.
2. Do not place batteries randomly in a parts box or other container. Discharge circuits will be formed by multiple batteries coming into contact numbers of the batteries, causing the batteries to discharge and drain.

○ Recommended procedures

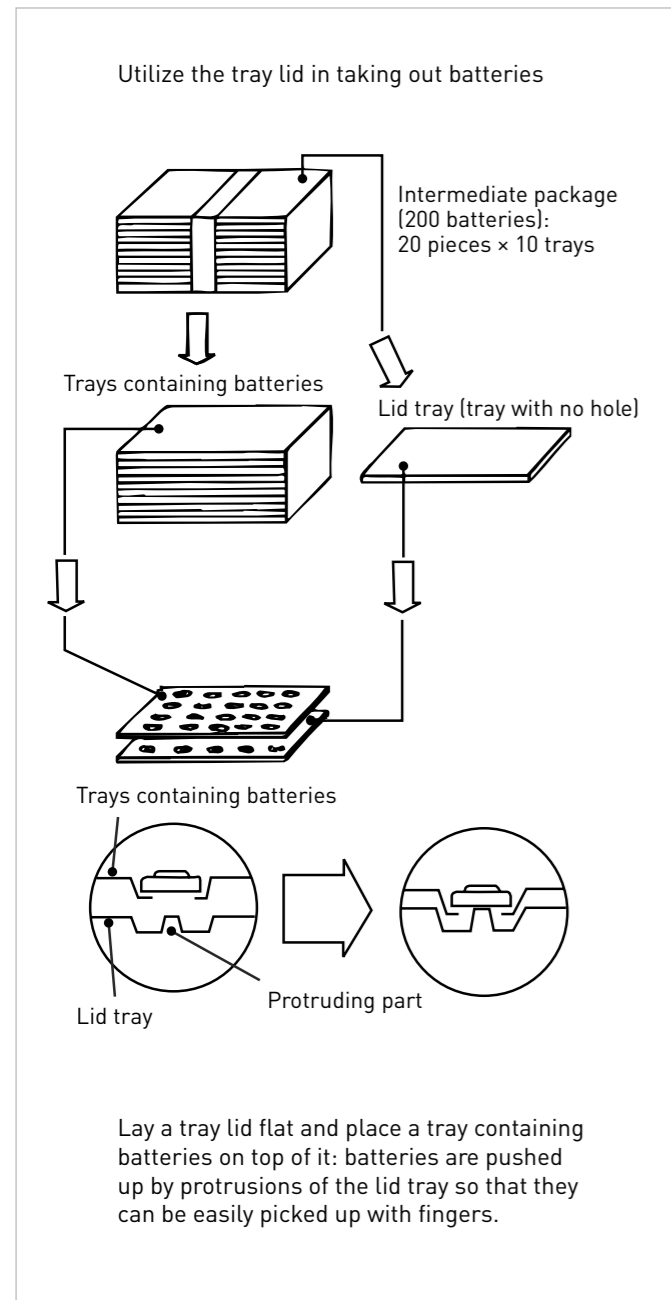

× Prohibited procedures

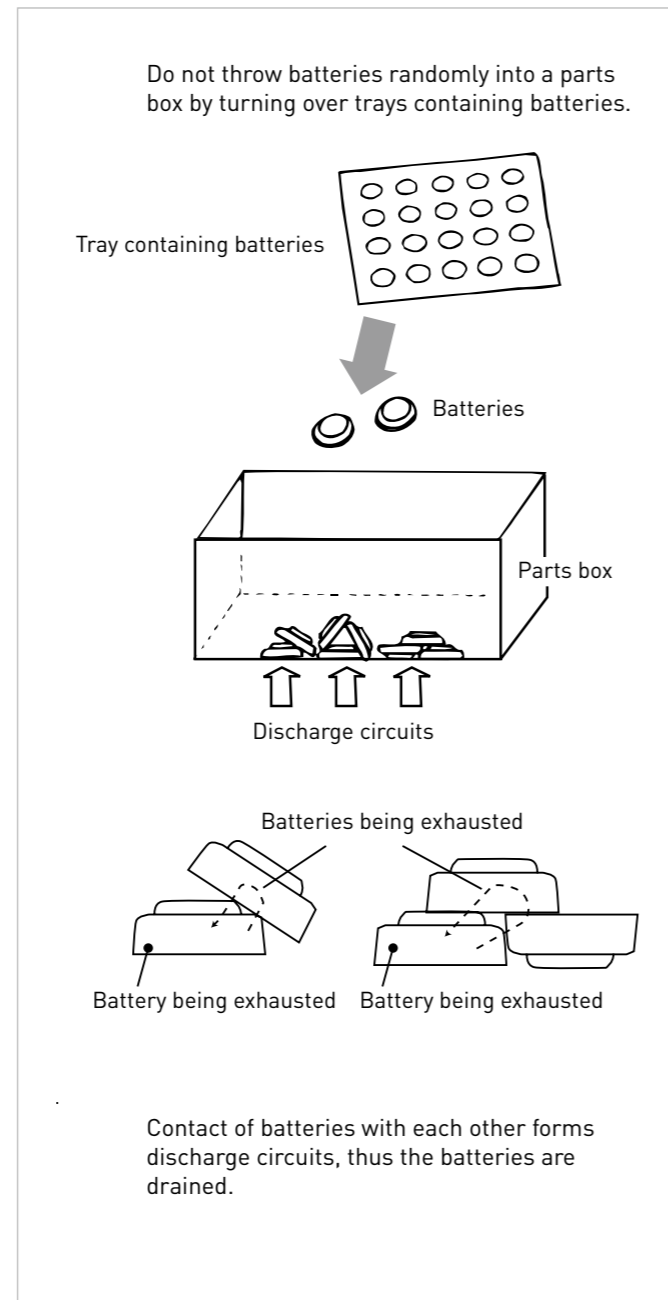

Memory Erasure Problems

Coin type Lithium batteries are often used as the power supplies for memory back-up in various equipment. However problems with the erasure of valuable data in the memory due to improper contact between the batteries and equipment have been reported.

1. When batteries are to be used continuously for a prolonged period.
 - Select tab terminal-mounted batteries, and solder the tabs to the battery connection terminals of the equipment. (See fig. 1)
 - When batteries need to be replaced, use a battery holder (see fig. 2) or battery with lead wire connectors (see fig. 3). Battery holders made by Panasonic (exclusively for the CR-2032 and BR-2032, see fig. 2) are available for use.
 2. When batteries need to be replaced in the short term, select batteries with no terminals or lead wire connectors.
 - Use of Y-shaped terminals (2-point contact) for both the anode and poles as the shape of the connection terminals in the equipment helps to achieve a more stable contact. (See fig. 4)
- The contact pressure of the contacts should be no less than 2 to 10N (approx. 200 to 1,000gf). (See fig. 5)
- To prevent momentary contact failure of several milliseconds in the circuit, the use of a tantalum capacitor, etc. with a capacitance of several microfarads is effective. (See fig. 6)
 - For the connection terminals of the equipment, use iron or stainless steel with nickel plating at the very least. Gold plating is more suitable when the contact resistance must be reduced.

Note: Do not touch batteries with bare hands because perspiration (salt), body oil, etc. will increase the surface resistance which may lead to defective contact.

Reference samples see Fig. 1-6

Fig. 1 Soldering

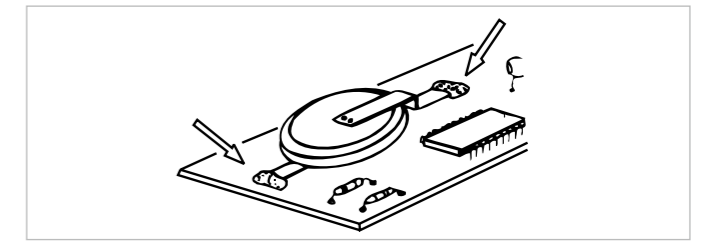

Fig. 2

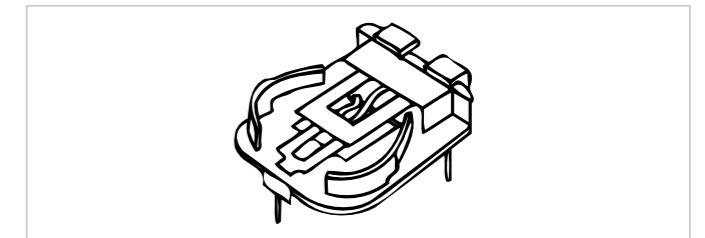

Fig. 3

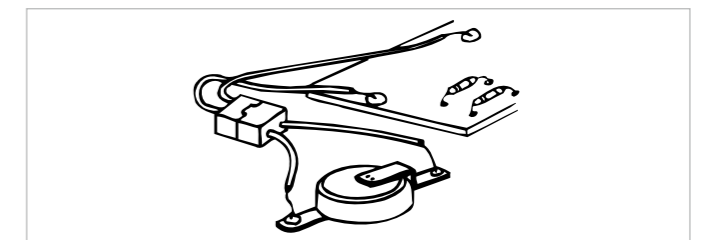

Fig. 4

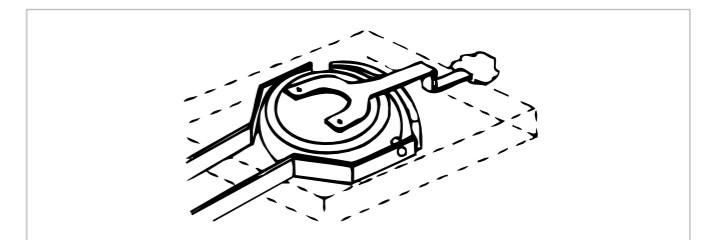

Fig. 5 Excessive load

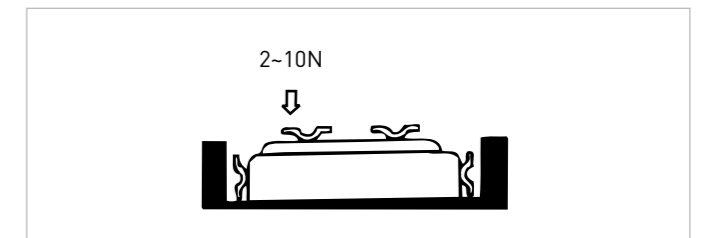

Fig. 6

