

Product Specification

for Ni-MH Battery

Model Number: Ni-MH D 1.2 V 9000mAh

Prepared By	Verified By	Approved By

Contents

1. SCOPE

This specification governs the performance of the following Everwin Tech Co., Limited Nickel- Hydride cylindrical Cell and its stack-up batteries.

Model: Ni-MH D 1.2V 9000mAh

The data involving nominal voltage and the approximate weight of stake-up batteries shall be equal to the value of the unit cell multiplied by the number of unit cells in the battery.

Nominal voltage of unit cell = 1.2V

2. RATINGS

Description	Unit	Specification	Conditions
Nominal Voltag	V	1.2V	
Nominal Capacity	mAh	9000	Standard Charge/discharge
Minimum Capacity	mAh	8900	Standard Charge/discharge
Standard Charge	mA	900(0.1C)	Ta=0~45°C
	hour	14-16	
Fast Charge	mA	0.3C	'- Δ V=0~5mV/cell , Timer Cutoff=120%nominal capacity , Temp.Cutoff=55°C, dT/dt=0.8°C/min, T1=-20±55°C
	hour	4 approx	
Trickle Charge	mA	0.03C ~ 0.05C	Ta=0~70 °C
Standard discharge	mA	1800(0.2C)	T1= -20±55°C Humidity: Max85%
Discharge Cut-off Voltage	V	1.0V	
Storage Temperature	°C	-20~30(Within 1 year)	Discharged state Humidity: Max85%
		-20~40(Within 6 months)	
		-20~50(Within 1 month)	
		-20~60(Within 1 week)	
Typical Weight	g	158	unit cell

3. PERFORMANCE

Unless otherwise stated, tests should be done within one month of delivery under the following conditions:

Ambient Temperature: Ta=20±5°C

Relative Humidity: 65±20%

Standard Charge/ Discharge Condition:

Charge: 900mA(0.1C)×16hrs

Discharge: 1800mA(0.2C)to 1.0V/ cell

Test	Unit	Specification	Conditions	Remarks
Capacity	mAh	≥8900	Standard Charge/Discharge	Up to 3 cycles are allowed
Open Circuit Voltage (OCV)	V	≥1.25	Within 1hr after standard charge	
Internal Impedance (Ri)	mΩ	≤9	Upon fully charge(1kHz) (1kHz)	
High Rate Discharge (1C)	min	≥51	Standard Charge,1hr rest before discharge	
Charge Retention	mAh	≥5400 (60%)	Standard Charge,Storage: 1months,Standard Discharge	
Leakage		No leakage nor deformation	Fully charged at 900mA 48 hrs	
IEC Cycle Life	Cycle	≥500	IEC61951-2(2003)7.4.1.1	see Note 3
Vibration Resistance		Change of voltage should be less than 0.02V/cell,Change of impedance should be less than 5 milli-ohm/cell	Charge the battery at 0.1C for 14hrs,then leave for 24hrs,check battery before/after vibration,amplitude 1.5mm,vibration 3000 CPM,any direction for 60mins.	
Impact Resistance		Change of voltage should be less than 0.02V/cell,change of impedance should be less than 5 milli-ohm/cell	Charge the battery at 0.1C for 14hrs,then leave for 24hrs,check battery before/after dropped,height 50 cm wooden board(thickness 30mm)direction not specified,3 times.	

4. CONFIGURATION, DIMENSIONS AND MARKINGS

Please refer to the attached drawing.

5. EXTERNAL APPEARANCE

The cell/ battery shall be free from cracks, scars, breakage, rust, Discoloration, leakage nor deformation.

6、 CAUTION

- [1] Reverse charging is not acceptable.
- [2] Charge before use. The cells/batteries are delivered in an uncharged state
- [3] Do not charge/discharge with more than our specified current.
- [4] Do not short circuit the cell/battery Permanent damage to the cells/batteries may result.
- [5] Do not incinerate or mutilate the cells/batteries.
- [6] Do not solder directly to the cells/batteries.
- [7] The expected life may be reduced if the cells/batteries are subjected to adverse conditions as: extreme temperature, deep cycling, excessive overcharge/ over-discharge.
- [8] Store the cells/batteries in a cool dry place. Always discharge batteries before packing.

Notes:

- [1] T1: Ambient Temperature.
- [2] Approximate charge time from discharged state, for reference only.
- [3] IEC61951-2(2003)7.4.1.1 Cycle Life:

Cycle No.	Charge	Rest	Discharge
1	0.1C × 16h	None	0.25C × 2h20min
2-48	0.25C × 3h10min	None	0.25C × 2h20min
49	0.25C × 3h10min	None	0.25C to 1.0V/cell
50	0.1C × 16h	1-4h	0.2C to 1.0V/cell
Cycle 1 to 50 shall be repeated until the discharge duration on any 50th cycle becomes less than 3 h.			

7. Specification

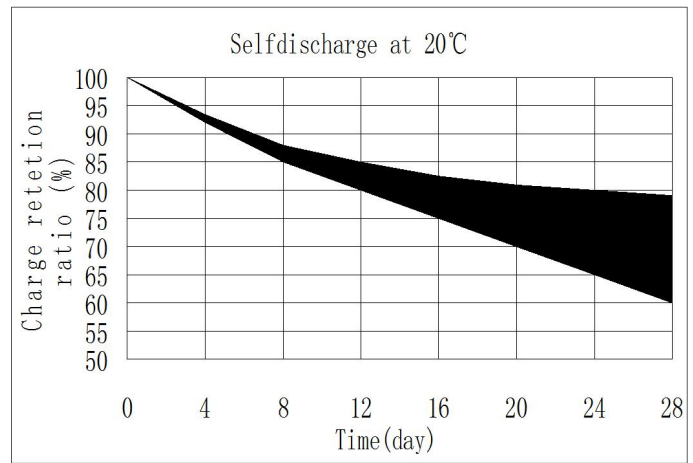
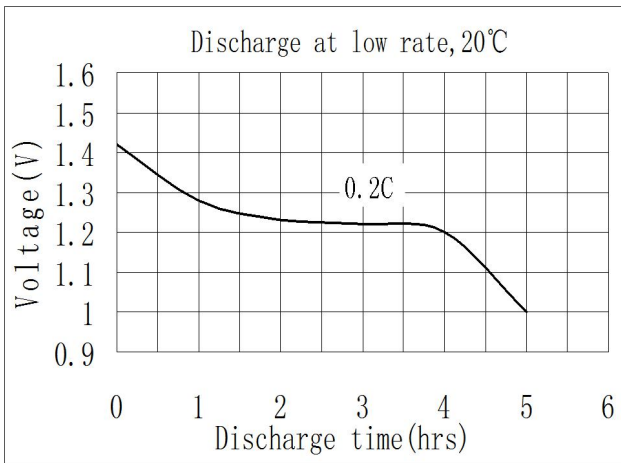
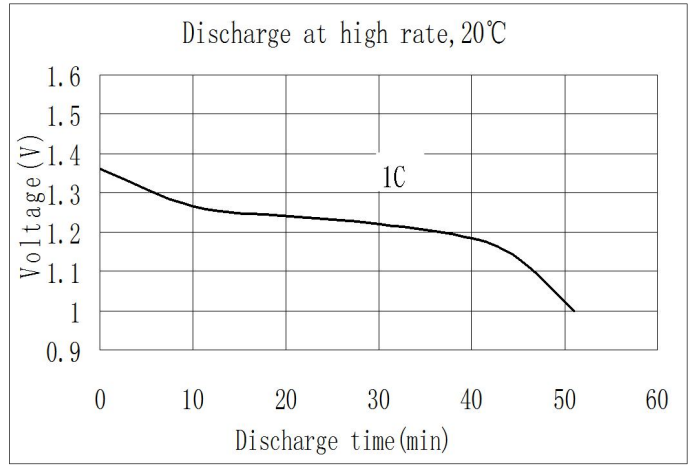
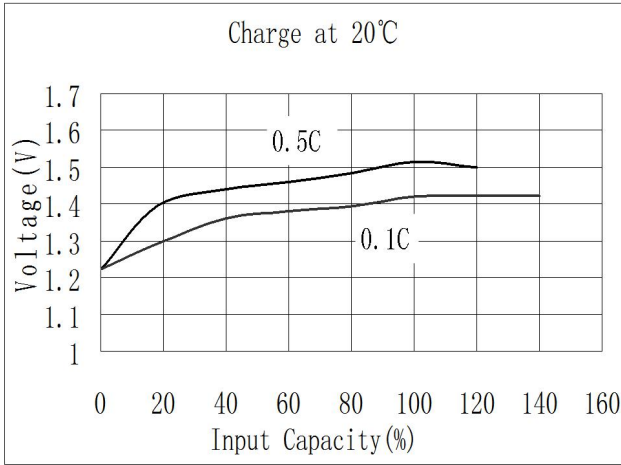

8. Draw

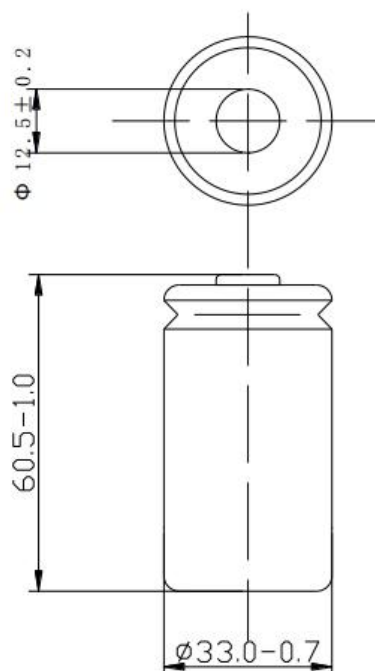

NOTICE: Any question you must apprise us in a week, or the standards will be accepted.