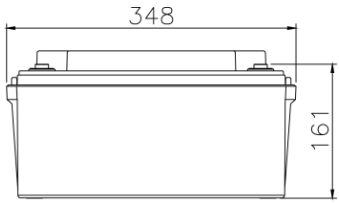
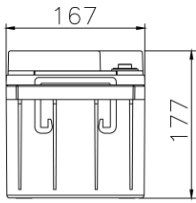
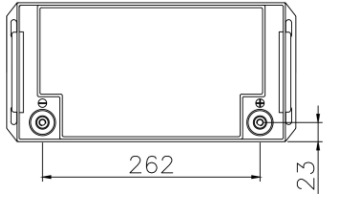
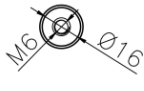

PRODUCT SHEET 12FGL70/L

TECHNICAL DATA		LAYOUT	
Voltage	12.00 V		
Performance	70Ah C20 1.75V/cell 25°C		
Float Voltage	2.27V/cell at 20°C		
Connection torque	7 - 9 Nm		
Max Charge Current	17.50 A		
Weight (Typical)	21,00 kg		
Internal Resistance	mOhm		
Short Circuit Current	A		

ELECTRICAL PERFORMANCES - Including Fiamm connection voltage drop

Constant Current Discharge Table [A] at 20°C

V / cell	5 min	10 min	15 min	30 min	45 min	1 h	2 h	3 h	4 h	5 h	6 h	8 h	10 h
1,60	195	147	115	71,9	52,3	41,4	23,2	17,1	13,5	11,3	9,60	7,57	6,24
1,65	188	143	113	71,0	51,7	40,9	23,0	16,9	13,4	11,2	9,53	7,51	6,20
1,67	180	139	111	70,1	51,2	40,6	22,8	16,8	13,2	11,0	9,43	7,44	6,15
1,70	176	136	110	69,6	50,9	40,4	22,6	16,7	13,2	11,0	9,36	7,39	6,11
1,75	164	130	106	68,1	50,0	39,9	22,2	16,4	12,9	10,8	9,19	7,25	5,98
1,80	149	121	100,0	65,2	48,3	38,6	21,7	15,9	12,5	10,4	8,91	7,05	5,84
1,85	112	95,0	81,2	55,9	42,6	34,5	19,9	14,7	11,6	9,72	8,31	6,56	5,43
1,90	23,8	23,3	22,3	18,5	15,2	13,3	9,78	7,99		5,70			3,15

Constant Power Discharge Table [W/cell] at 25°C

V / cell	5 min	10 min	15 min	30 min	45 min	1 h	2 h	3 h	4 h	5 h	6 h	8 h	10 h
1,60	346	266	216	138	102	81,6	46,6	33,7	26,7	22,3	19,1	15,0	12,4
1,65	330	258	211	136	101	80,9	46,2	33,5	26,6	22,3	19,0	15,0	12,4
1,67	322	254	209	135	100	80,6	46,0	33,3	26,4	22,1	18,9	14,9	12,3
1,70	310	247	205	134	99,6	80,0	45,5	33,1	26,2	21,9	18,7	14,8	12,3
1,75	290	236	199	132	98,2	79,3	45,1	32,7	25,9	21,7	18,5	14,6	12,1
1,80	268	224	190	127	95,5	77,2	44,2	32,0	25,2	21,0	18,0	14,2	11,8
1,85	208	182	159	113	87,3	71,6	41,9	30,5	24,1	20,1	17,2	13,6	11,2
1,90													