



MP0,8-12AMP

Nominal Voltage (V) 12V

Nominal Capacity

20hour rate (0.04A to 10.50V)	0.8Ah
10hour rate (0.08A to 10.50V)	0.8Ah
5hour rate (0.136A to 10.20V)	0.68Ah
1C (0.8A to 9.60V)	0.36Ah
3C (2.4A to 9.60V)	0.288Ah

Weight 0.37kg(0.82Lbs.)

Internal Resistance (at 1KHz) 125 mΩ

Maximum Discharge Current for 30 seconds : 16A

Maximum Discharge Current for 5 seconds : 32A

Operating Temperature Range

Charge	0°C (32°F) to 40°C (104°F)
Discharge	-15°C (5°F) to 50°C (122°F)
Storage	-15°C (5°F) to 40°C (104°F)

Charge Retention (shelf life) at 20°C (68°F)

1 month	92%
3 month	90%
6 month	80%

Charging Methods at 25°C (77°F)

Cycle use:
 Charging Voltage 14.4 to 15.0V
 Maximum Charging Current: 0.24A

Standby use:
 Float Charging Voltage 13.50 to 13.80V

Life expectancy :

Cycle Use:
 100% depth of discharge 200 cycles
 80% depth of discharge 225 cycles
 50% depth of discharge 500 cycles

Standby Use: 3-5 years

Case Material ABS
 (Option: 94-HB & 94V-0 flame retardant case)

Terminal WIRE

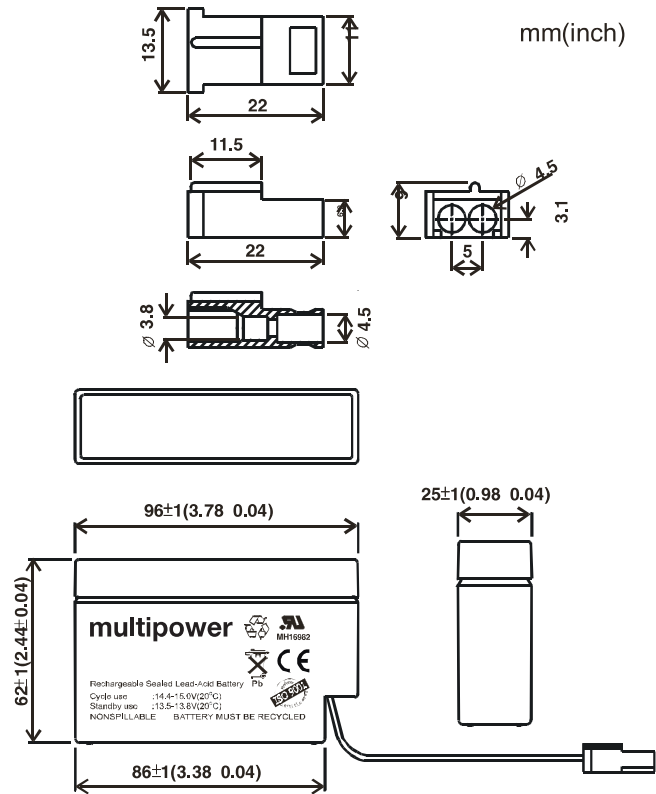

(v) FOR 12V BATTERY **Discharge Time VS. Discharge Current (25°C)**

